

HALLENBAD MIT RUTSCHE

INDOOR SWIMMING-POOL WITH SLIDE
PISCINE COUVERTE AVEC TOBOGGAN
OVERDEKT ZWEMBAD MET GLIJBAAAN

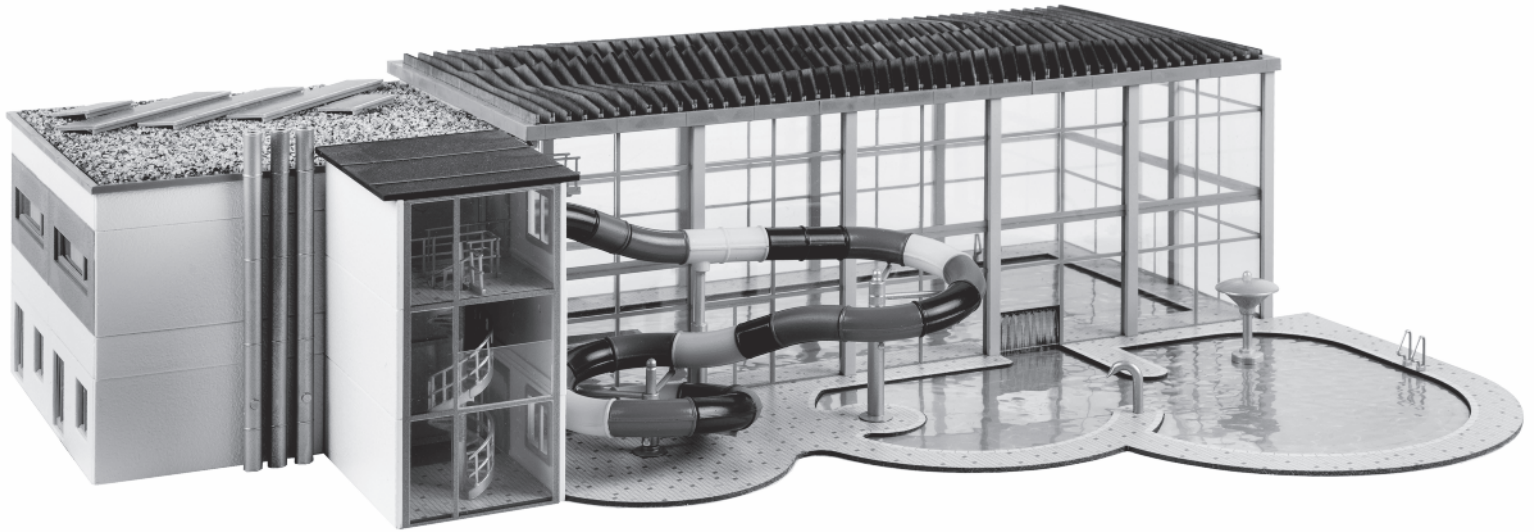

Art. Nr. 130150



Inhalt	Spritzling	1 ACE HM	1 x	2	1 x	4 B	1 x	5 C	1 x	7 A	1 x	7 A III	1 x	8 AB	1 x	11 AB	2 x	12 AB	2 x	14	1 x
Contents	Sprues	1 ADE HM	1 x	3 B	1 x	4 C	2 x	6 A	4 x	7 A	1 x	7 A III	7 x	9	1 x	11 C	2 x	12 D	2 x	15	1 x
Contenu	Moulages																				
Inhoud	Gietstukken	1 AE GH	4 x	3 C	1 x	5 A P	2 x	6 C	1 x	7 A I	2 x	7 B	2 x	9 A	1 x	12 A	1 x	13	1 x	16	1 x

Sa. Nr. 130 150 1

(D)

Vor Beginn des Bastelns sollten Sie sich mit den Spritzlingen und der Anleitung vertraut machen. Sollte es einmal vorkommen, dass ein Teil im Bausatz fehlt, kreuzen Sie bitte das fehlende Teil in der Anleitung an und schicken Sie diese bitte an Fa. Gebr. FALLER GmbH, Abt. Kundendienst, kundendienst@faller.de, Kreuzstraße 9, 78148 Gütenbach. Sie erhalten dann umgehend Ersatz. Es kann vorkommen, dass bei einem Bausatz Einzelteile übrig sind.

(GB)

Before beginning with the assembly please familiarize yourself with the parts and read the instructions carefully. In case of missing parts please indicate these on the instructions leaflet with a circle and return the leaflet to Gebr. FALLER GmbH, kundendienst@faller.de, Kreuzstraße 9, D-78148 Gütenbach, Germany. You will receive the replacement by return. It may happen in a kit that some parts are not required.

(F)

Avant de commencer le montage de votre maquette bien lire la notice et repérer les grappes. Si une pièce manque dans une boîte, cochez la pièce correspondante sur la notice et renvoyez-la-nous à Gebr. FALLER GmbH, kundendienst@faller.de, Kreuzstraße 9, D-78148 Gütenbach (R.F.A.). Nous vous ferons parvenir la pièce par retour. Dans certains kits, il est possible que certaines pièces ne soient pas utilisées.

(NL)

Vóór het bouwen zou men de gietstukken en de handleiding moeten bestuderen. Indien onverhoopt een onderdeel aan het bouwpakket ontbreekt, gelieve men het ontbrekende deel in de handleiding aan te kruisen en deze te zenden aan Gebr. FALLER GmbH, kundendienst@faller.de, Kreuzstraße 9, D-78148 Gütenbach. U ontvangt dan omgaand en gratis het ontbrekende onderdeel. Het kan voorkomen dat u bij bepaalde bouwdozen onderdelen overhoudt.

Für den Zusammenbau des Modells empfehlen wir folgende FALLER-Artikel (sind nicht im Bausatz enthalten):
For the assembly of the kit we recommend following FALLER products (not included in the kit):
Pour l'assemblage du modèle, nous vous recommandons les articles FALLER suivants (non inclus dans le kit):
Om dit model te bouwen adviseren wij de volgende FALLER producten (maken geen deel uit van deze bouwset):

Art. Nr. 170492
FALLER-EXPERT

Flüssigkleber in Plastikflasche mit Spezialkanüle für feinste Klebstoffdosierung.

Liquid cement in plastic bottle with canule for very fine dosage.

Colle liquide en bouteille plastique avec bec verseur pour un dosage précis.

Vloeibare lijm in plastic-flesje met doseerbuisje om nauwkeurig te lijmen.



Art. Nr. 170688
SPEZIAL-SEITENSCHNEIDER

zum gratfreien Abtrennen von feinsten Spritzteilen. Nur für Polystyrol geeignet.

Special side cutter for cutting off ultra-fine moulded parts without burrs. Only suitable for polystyrene.

Pince coupante spéciale pour couper sans bavure les pièces miniatures moulées par injection. Convient uniquement au polystyrène.

Speciale zijknijptang voor het braamloos afknippen van de fijnste gietstukdelen. Alleen geschikt voor polystyrol.



(D)

Für die Montage benötigen Sie:
FALLER-Klebstoff EXPERT (Art. Nr. 170492)
FALLER-EXPERT LASERCUT (Art. Nr. 170494)
FALLER-Colofix (Art. Nr. 170501)
Alleskleber
FALLER-Spezial-Seitenschneider (Art. Nr. 170688)
FALLER-Bastelmesser (Art. Nr. 170687)
VALLEJO Blaugrau, hell, Matt, 17 ml (Art. Nr. 770907)

(GB)

For mounting you need:
FALLER cement EXPERT (Item no. 170492)
FALLER EXPERT LASERCUT (Item no. 170494)
FALLER-Colofix (item no. 170501)
All-purpose glue
FALLER special side cutter (Item no. 170688)
FALLER modeller's knife (Item no. 170687)
VALLEJO blue gray, bright, flat, 17 ml (Item no. 770907)

(F)

Pour le montage, utiliser :
Colle FALLER EXPERT (Art. 170492)
FALLER EXPERT LASERCUT (Art. 170494)
FALLER-Colofix (Art. 170501)
Colle universelle
Pince coupante diagonale spéciale FALLER (Art. 170688)
Couteau de bricolage FALLER (Art. 170687)
VALLEJO bleu gris, clair, mat, 17 ml (Art. 770907)

(NL)

Voor de montage heeft u :
FALLER-plasticlijm EXPERT (Art. 170492)
FALLER EXPERT LASERCUT (Art. 170494)
FALLER-Colofix (Art. 170501)
Universele lijm
FALLER-speciaal zijknijptang (Art. 170688)
FALLER-knutselmes (Art. 170687)
VALLEJO blauw grijs, helder, mat, 17 ml (Art. 770907)

Fensterfolie: Die beiliegende Fensterfolie entsprechend der benötigten Größe ausschneiden und vorsichtig mit wenig Klebstoff auf die Rückseite der Fensterrahmen aufkleben.

Window foil: Cut the attached window foil according the illustrations and glue it carefully with a little glue to the rear side of the window frames.

Feuillet transparent pour fenêtres: Découper le feuillet transparent pour fenêtres inclus d'après l'illustration. Coller proprement avec un peu de colle sur la face arrière du cadre des fenêtres.

Vensterfolie: De meegeleverde vensterfolie conform de afbeeldingen uitknippen of uitsnijden en voorzichtig met een beetje lijm op de achterzijde van het raam plakken.

7/1 Rahmen vorne
Frame in front
Cadre devant
Frame vooraan

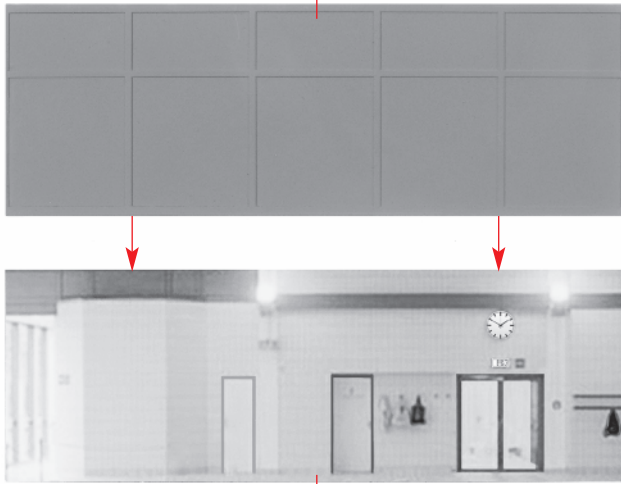

Nur wenig Kleber verwenden!
Use only a little glue!
Utilisez seulement un peu de colle!
Gebruik slechts een beetje lijm!

A

7/1

1/17

1/17



B

A

Fensterfolie
Window foil
Feuillet transparent
Vensterfolie

1/15

Fensterfolie
Window foil
Feuillet trans.
Vensterfolie

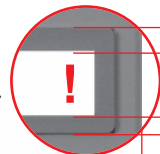

1/7 H

1/7 H

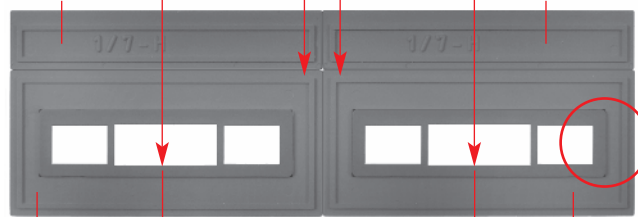

5/1 P

4/4

4/4

5/1 P

C

D 2 x

1/17

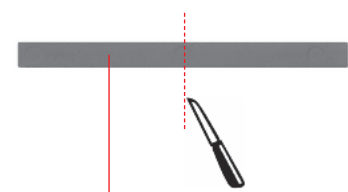

1/19 **D**

Fensterfolie
Window foil
Feuillet transparent
Vensterfolie

5/7

D 1/12

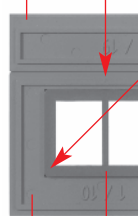

1/10 3/7

5/6

3/9 1/13

E

F

E

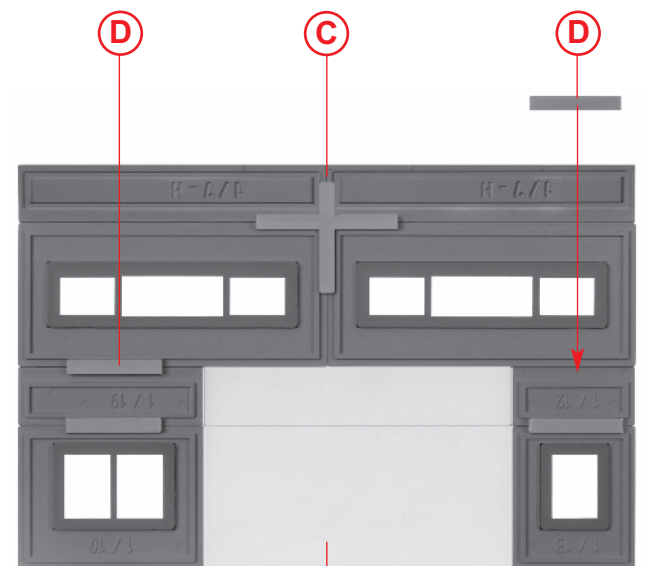

Fensterfolie
Window foil
Feuillet transparent
Vensterfolie

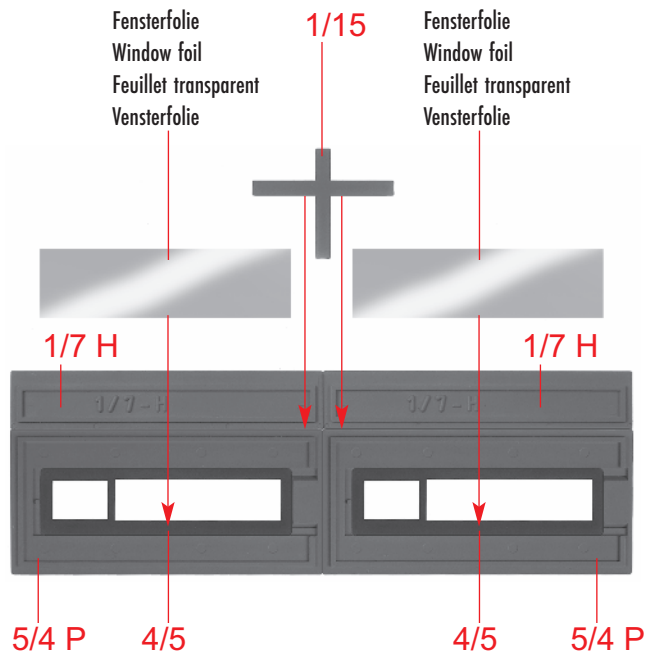

G

Fensterfolie
Window foil
Feuillet transparent
Vensterfolie

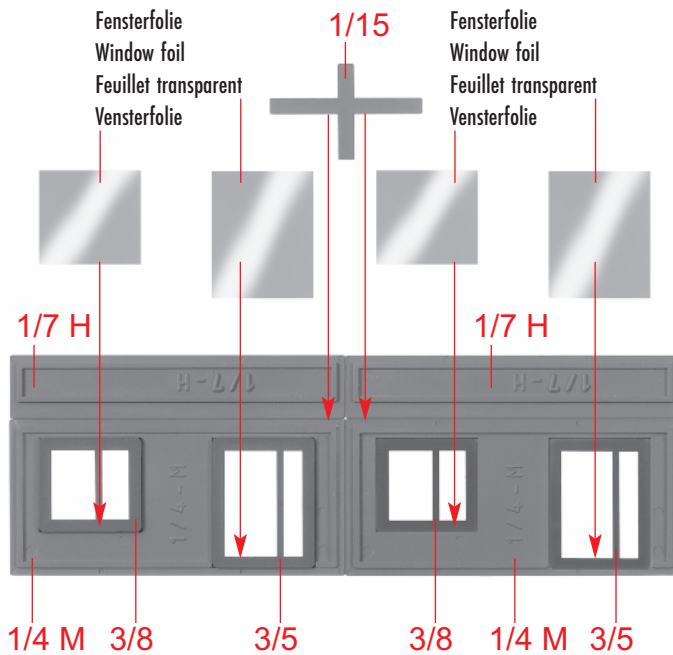

H

1/17

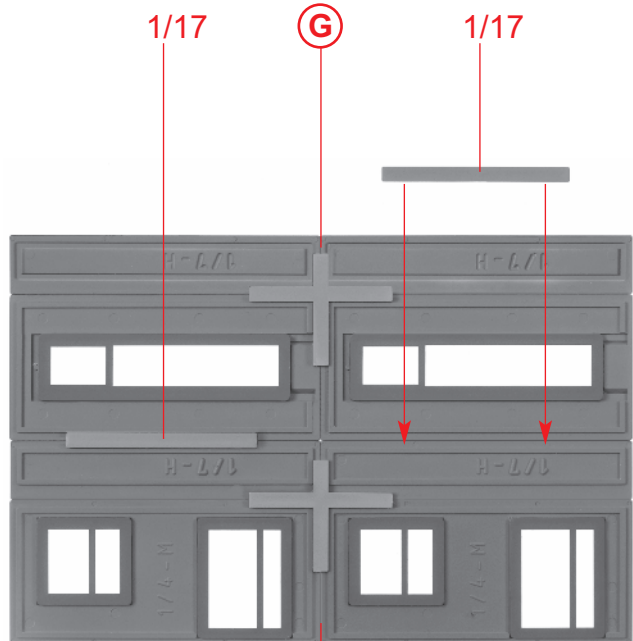

I

G

H

1/17 1/15 1/17

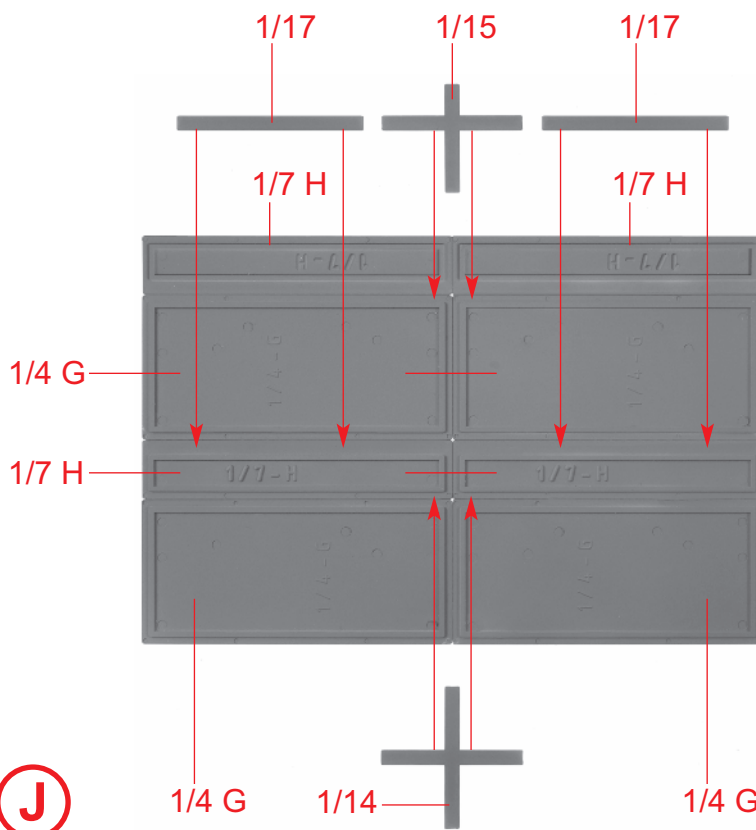

J

B

J

I

F

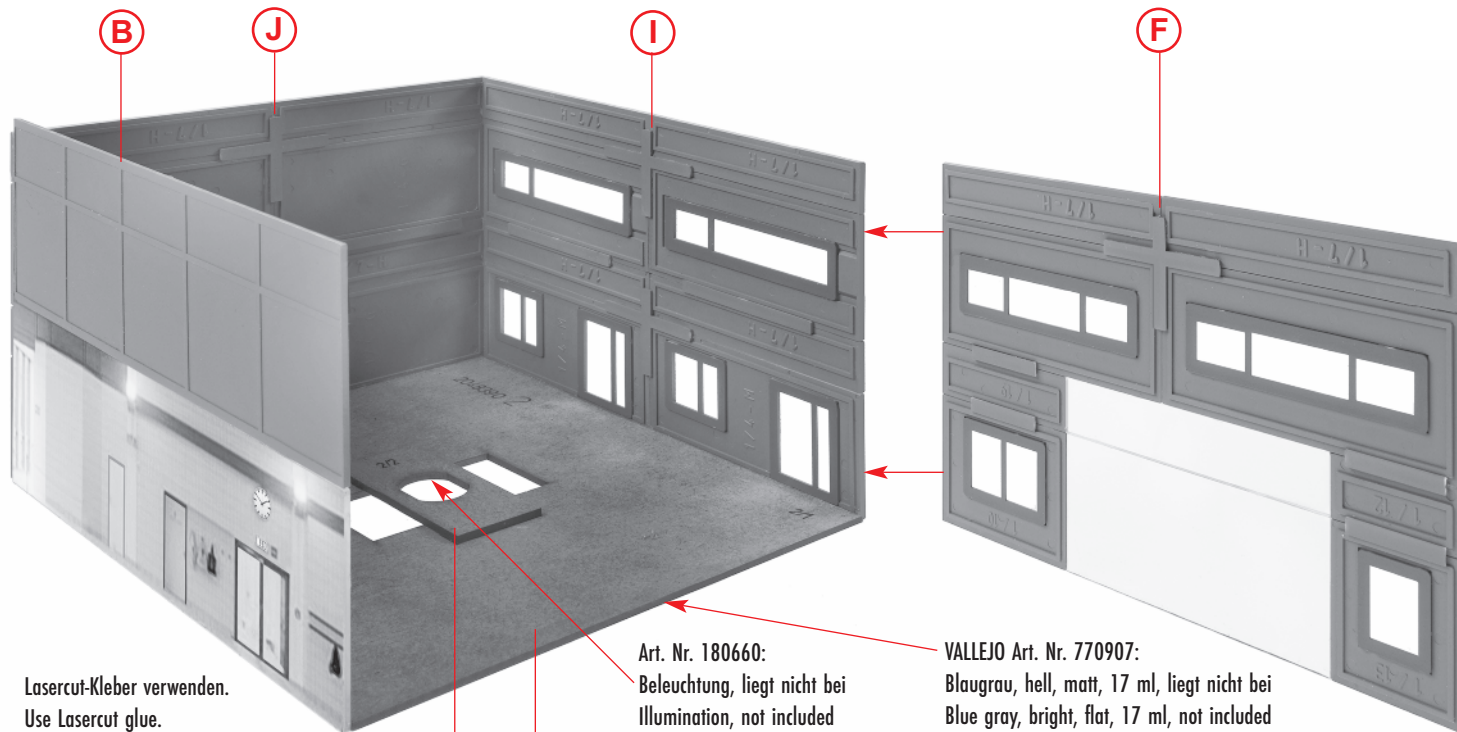

K

Lasercut-Kleber verwenden.
Use Lasercut glue.
Utilisez la colle Lasercut.
Gebruik Lasercutlijm.

Art. Nr. 180660:
Beleuchtung, liegt nicht bei
Illumination, not included
Eclairage, non jointe
Verlichting, niet bijgevoegd

VALLEJO Art. Nr. 770907:
Blaugrau, hell, matt, 17 ml, liegt nicht bei
Blue gray, bright, flat, 17 ml, not included
Bleu gris, clair, mat, 17 ml, non jointe
Blauw grijs, helder, mat, 17 ml, niet bijgevoegd

4

Art. Nr. 180501:
COLOFIX, liegt nicht bei
COLOFIX, not included
COLOFIX, non jointe
COLOFIX, niet bijgevoegd

Inhalt Tüte
Contents bag
Contenu sachet
Inhoud zakje

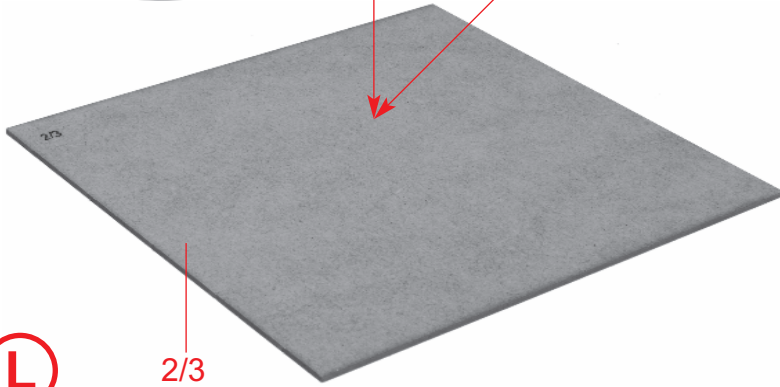
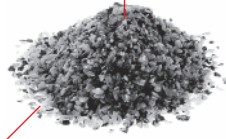

(M) 2 x 6/16

(N) 3 x 6/15

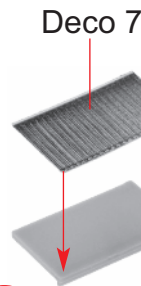

Deco 7

Mit Alleskleber kleben.
Use all-purpose glue.
Utiliser de la colle universelle.
Met een universele lijm lijmen.

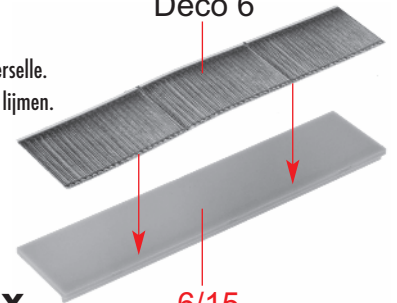

Deco 6

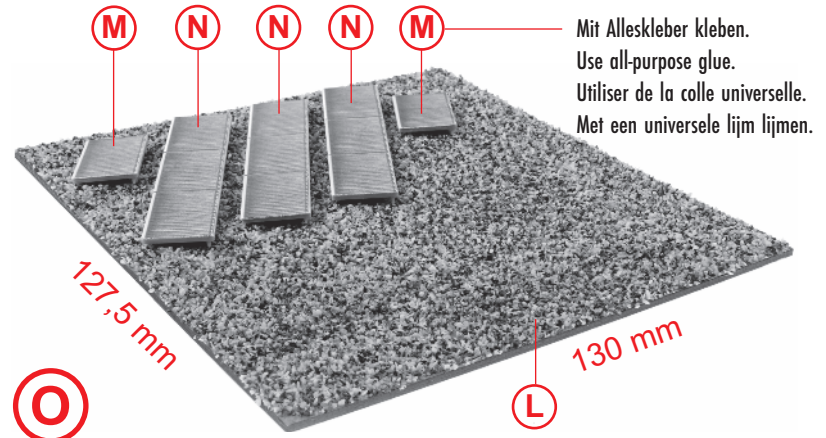

Mit Alleskleber kleben.
Use all-purpose glue.
Utiliser de la colle universelle.
Met een universele lijm lijmen.

(L)

2/3

(O)

127,5 mm

130 mm

(L)

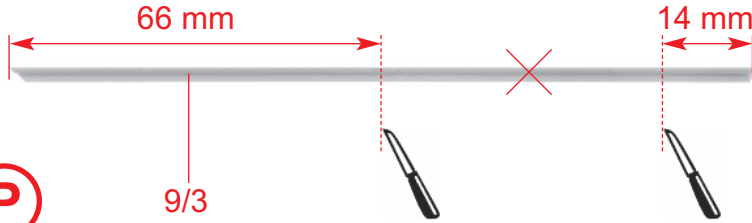

(P)

9/3

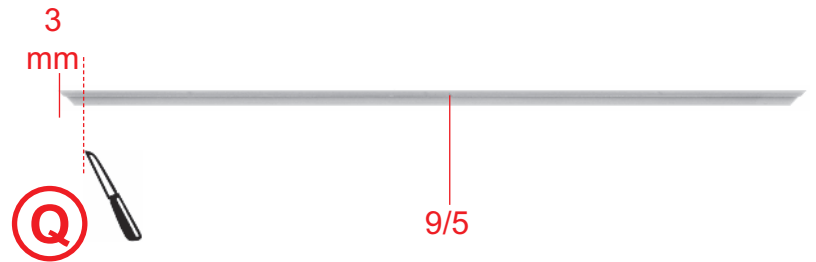

(Q)

9/5

Lasercut-Kleber verwenden.
Use Lasercut glue.
Utilisez la colle Lasercut.
Gebruik Lasercutlijm.

(O)

Papiermaske
Papermask
Masque
Masker **M1**

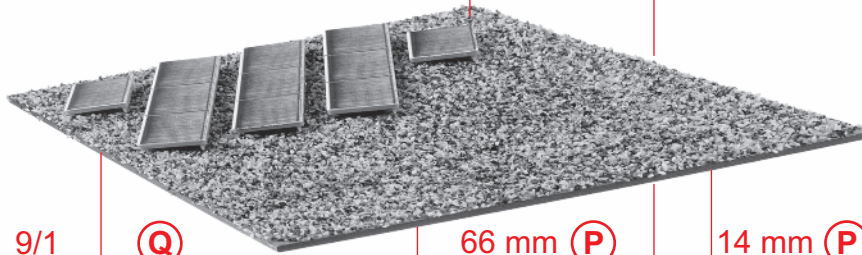

9/1

(Q)

66 mm

(P)

14 mm

(P)

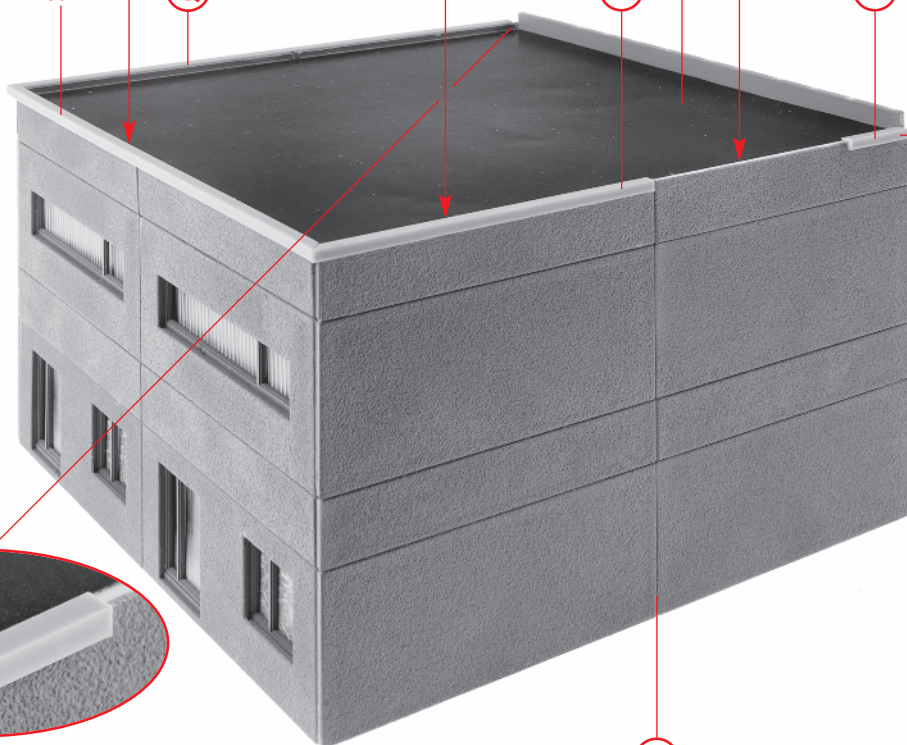

2,5 mm

(R)

(K)

2,5 mm

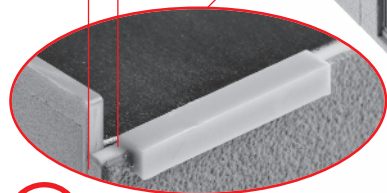
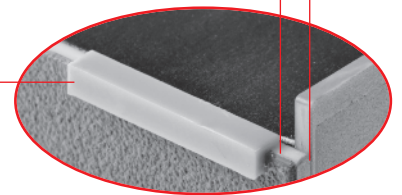

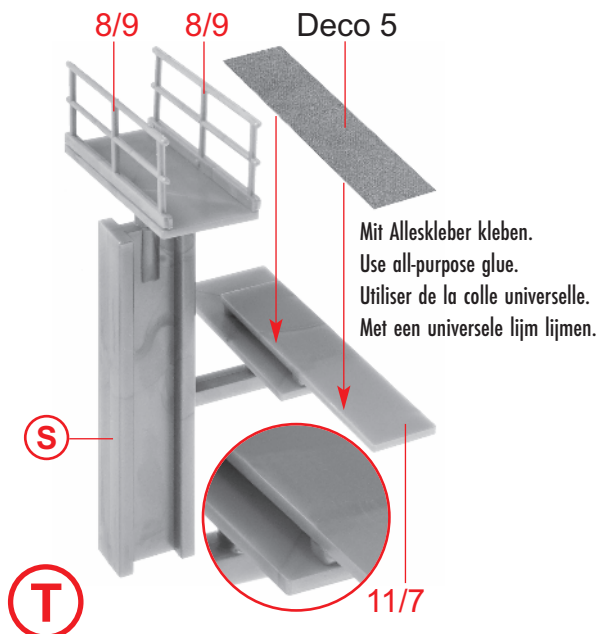
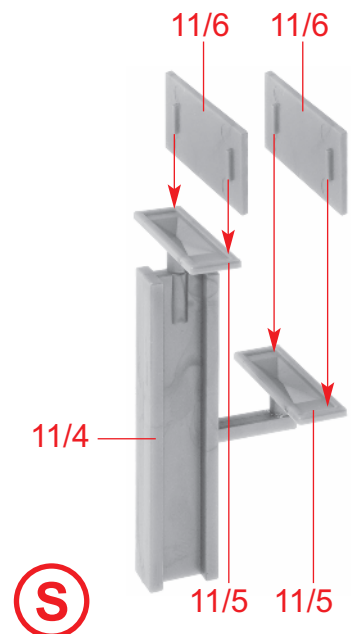

Mit Alleskleber kleben.
Use all-purpose glue.
Utiliser de la colle universelle.
Met een universele lijm lijmen.

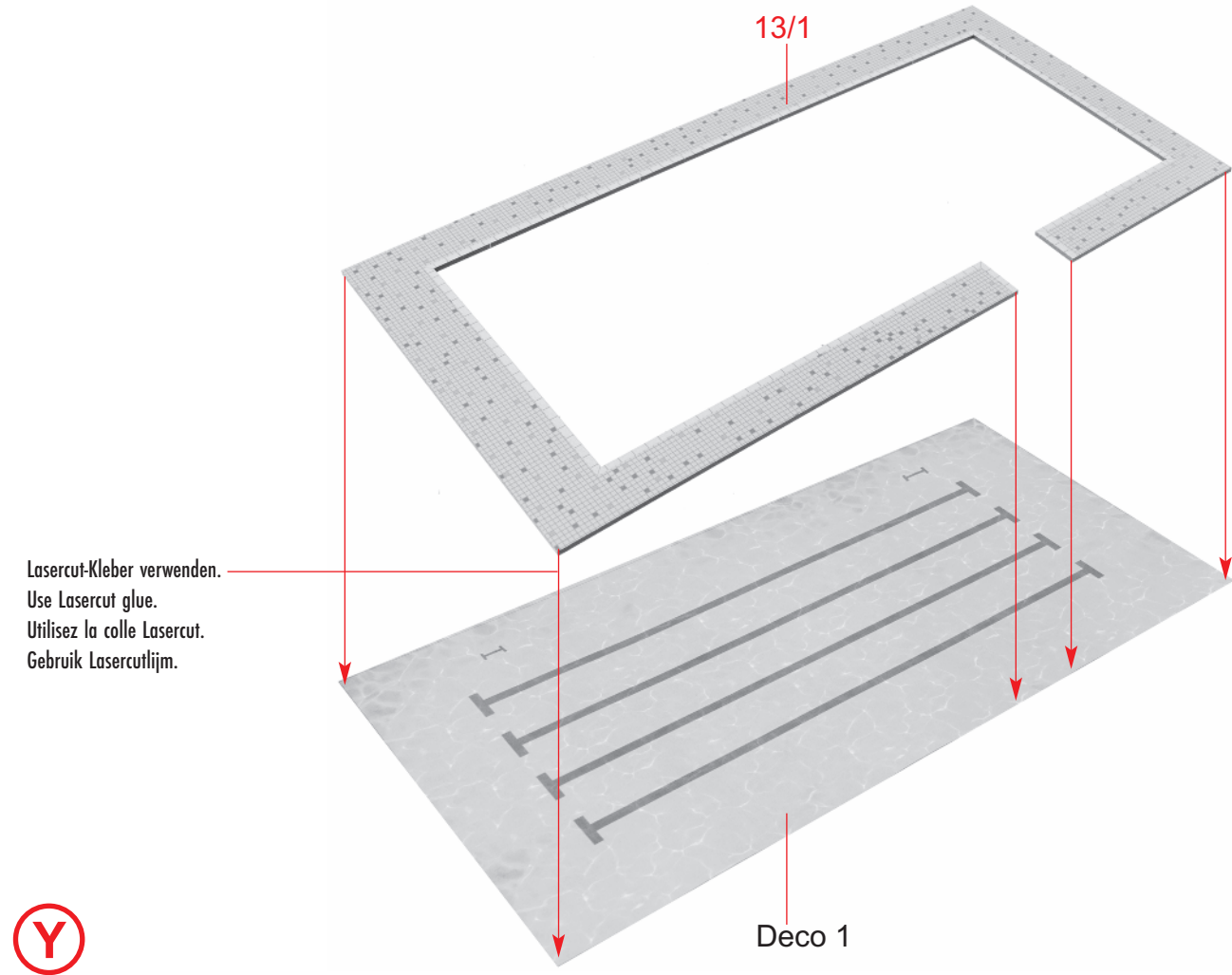
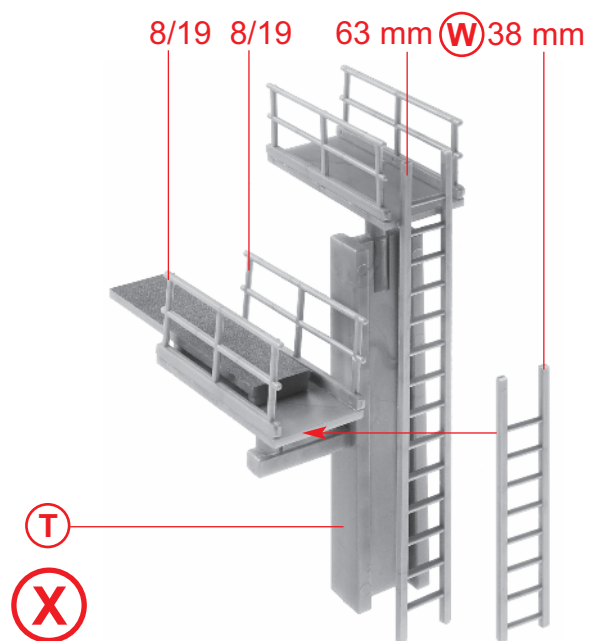
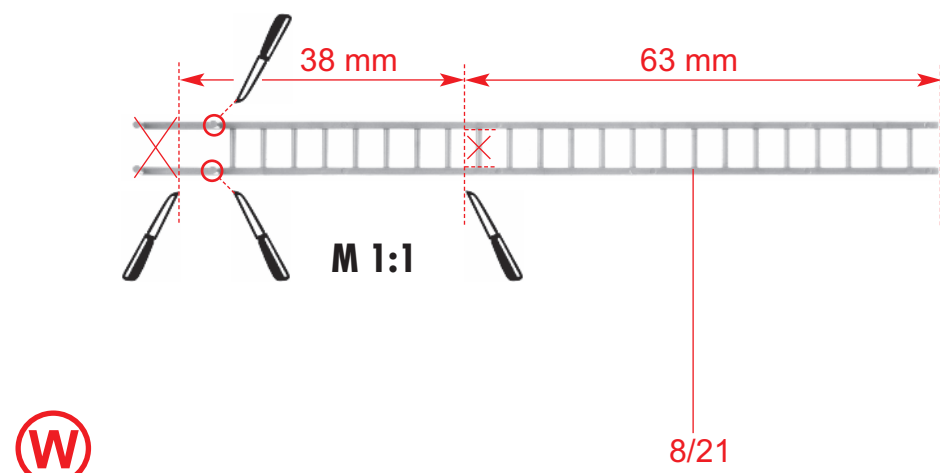
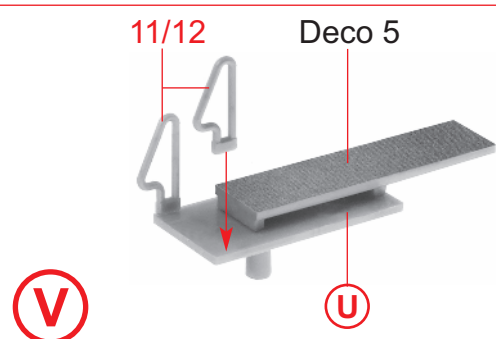
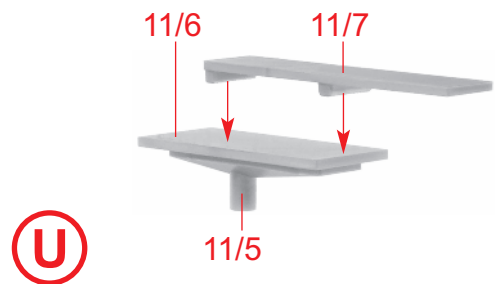

Lasercut-Kleber verwenden.
Use Lasercut glue.
Utilisez la colle Lasercut.
Gebruik Lasercutlijm.

6 Lasercut-Kleber verwenden.
 Use Lasercut glue.
 Utilisez la colle Lasercut.
 Gebruik Lasercutlijm.

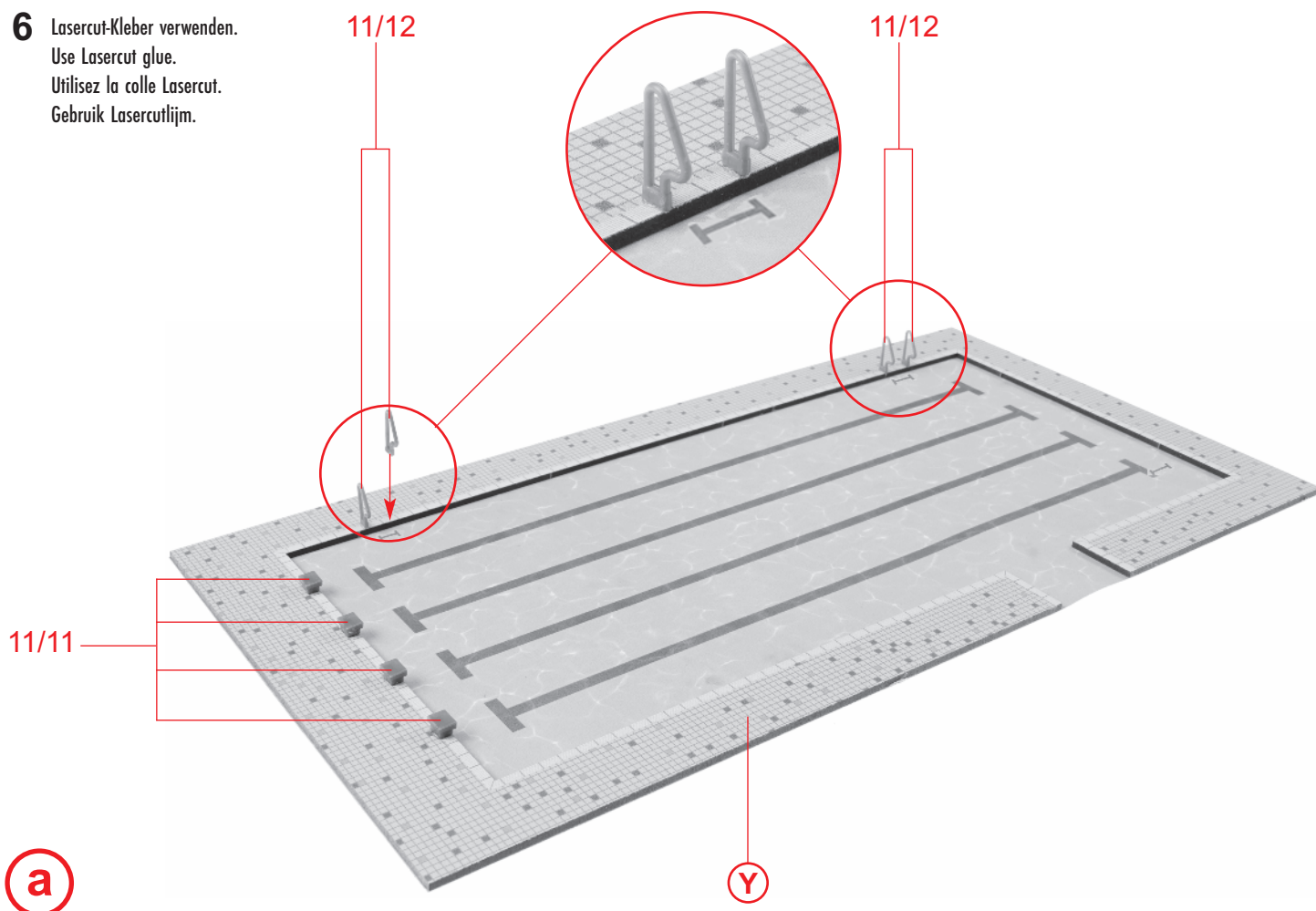

Lasercut-Kleber verwenden.
 Use Lasercut glue.
 Utilisez la colle Lasercut.
 Gebruik Lasercutlijm.

Wasserfolie
 Water folie
 Feuille d'eau
 Waterfolie

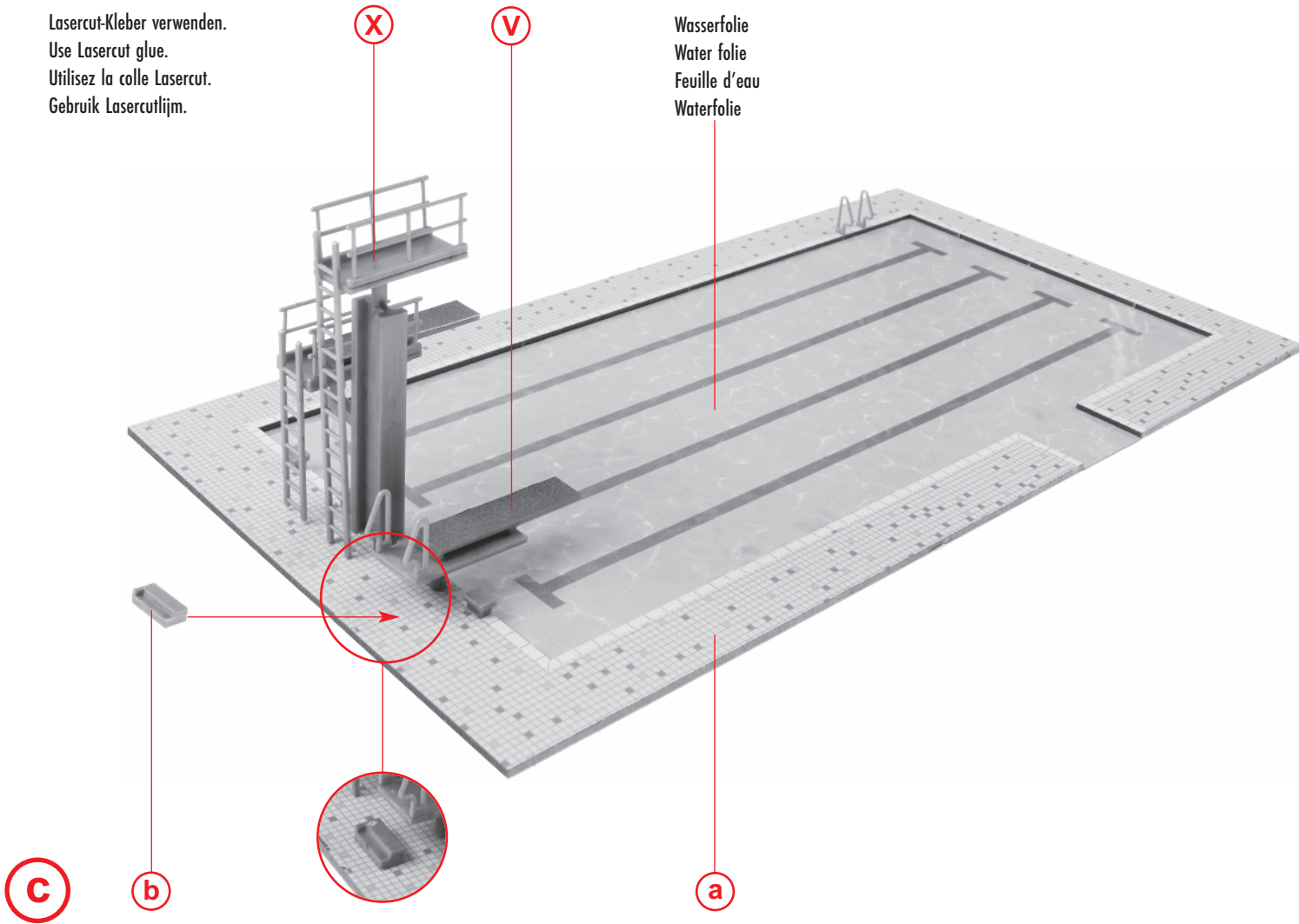

Nur wenig Kleber verwenden!
Use only a little glue!
Utilisez seulement un peu de colle!
Gebruik slechts een beetje lijm!

7/1 III
7/1 I
Rahmen vorne
Frame in front
Cadre devant
Frame vooraan

d

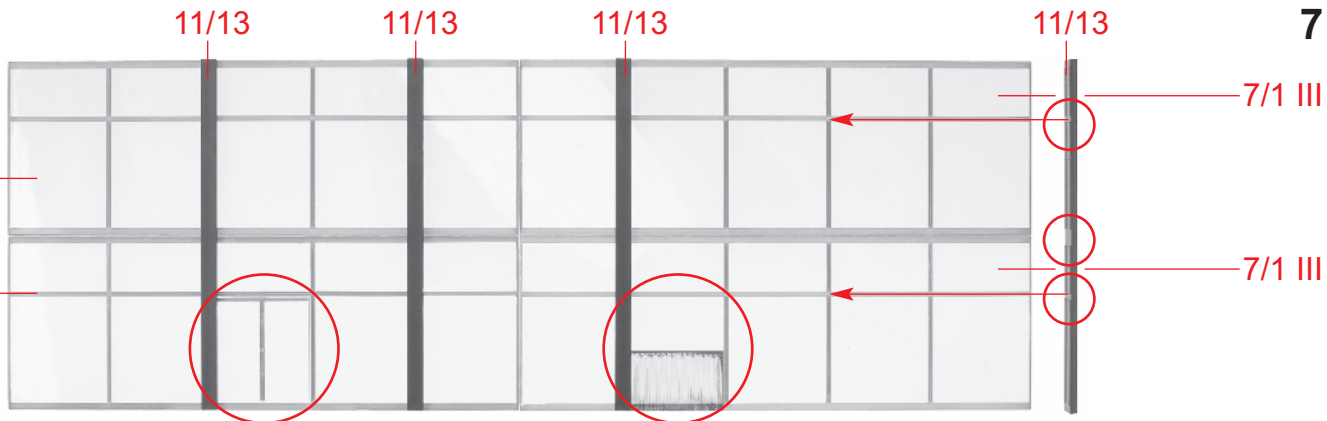

d

e

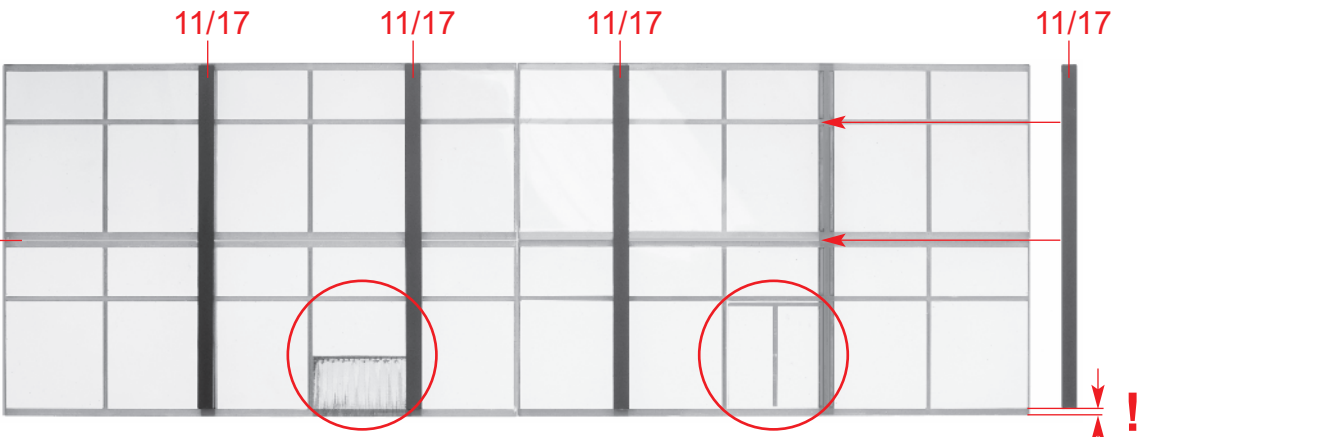

7/1 III
Rahmen vorne
Frame in front
Cadre devant
Frame vooraan
7/1 I

f

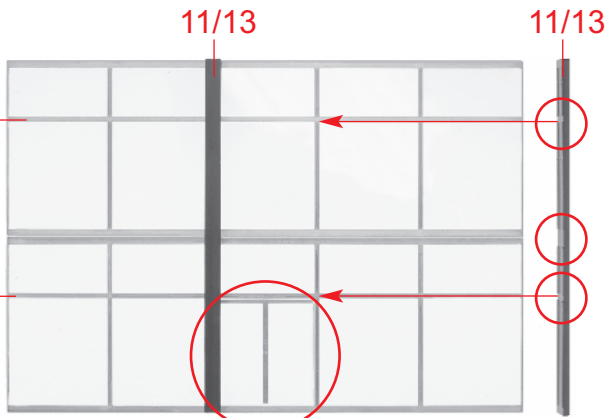

f

g

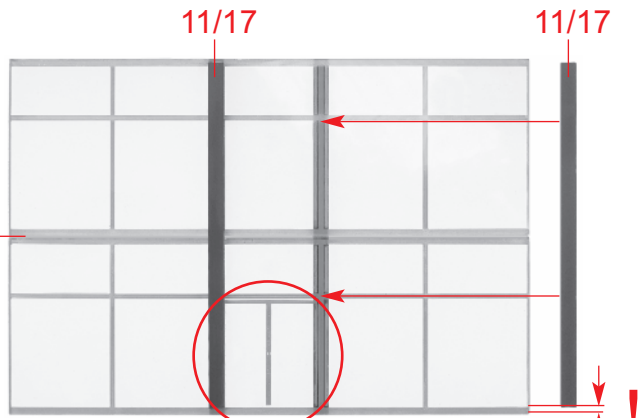

Nur wenig Kleber verwenden!
Use only a little glue!
Utilisez seulement un peu de colle!
Gebruik slechts een beetje lijm!

7/1 III
7/1 III
Rahmen vorne
Frame in front
Cadre devant
Frame vooraan

h

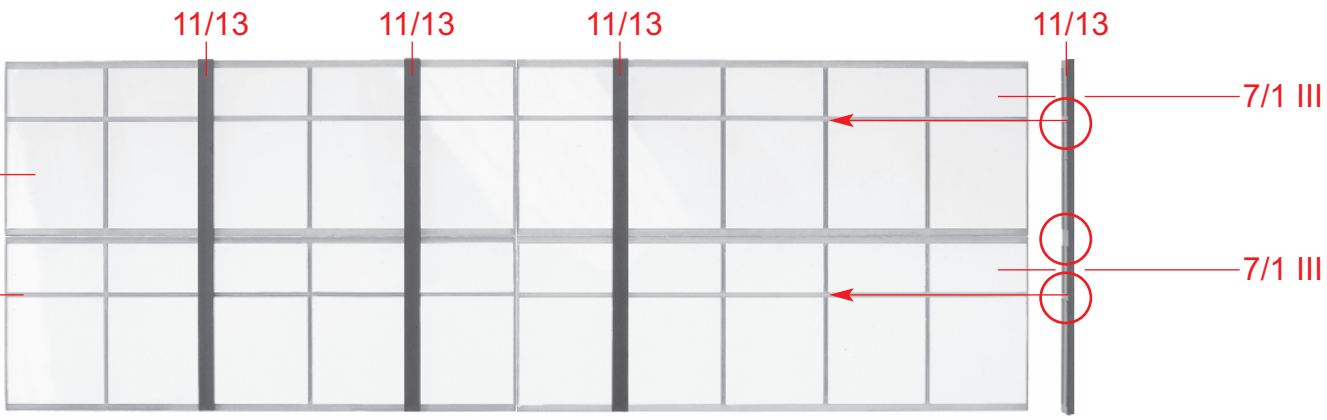

Nur wenig Kleber verwenden!
Use only a little glue!
Utilisez seulement un peu de colle!
Gebruik slechts een beetje lijm!

h

i

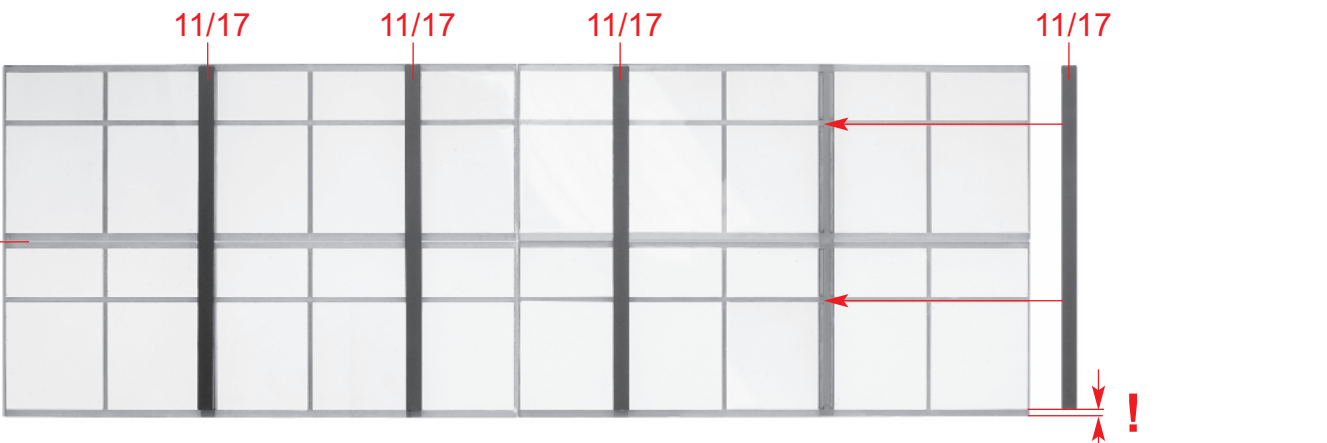

8 Lasercut-Kleber verwenden.
Use Lasercut glue.
Utilisez la colle Lasercut.
Gebruik Lasercutlijm.

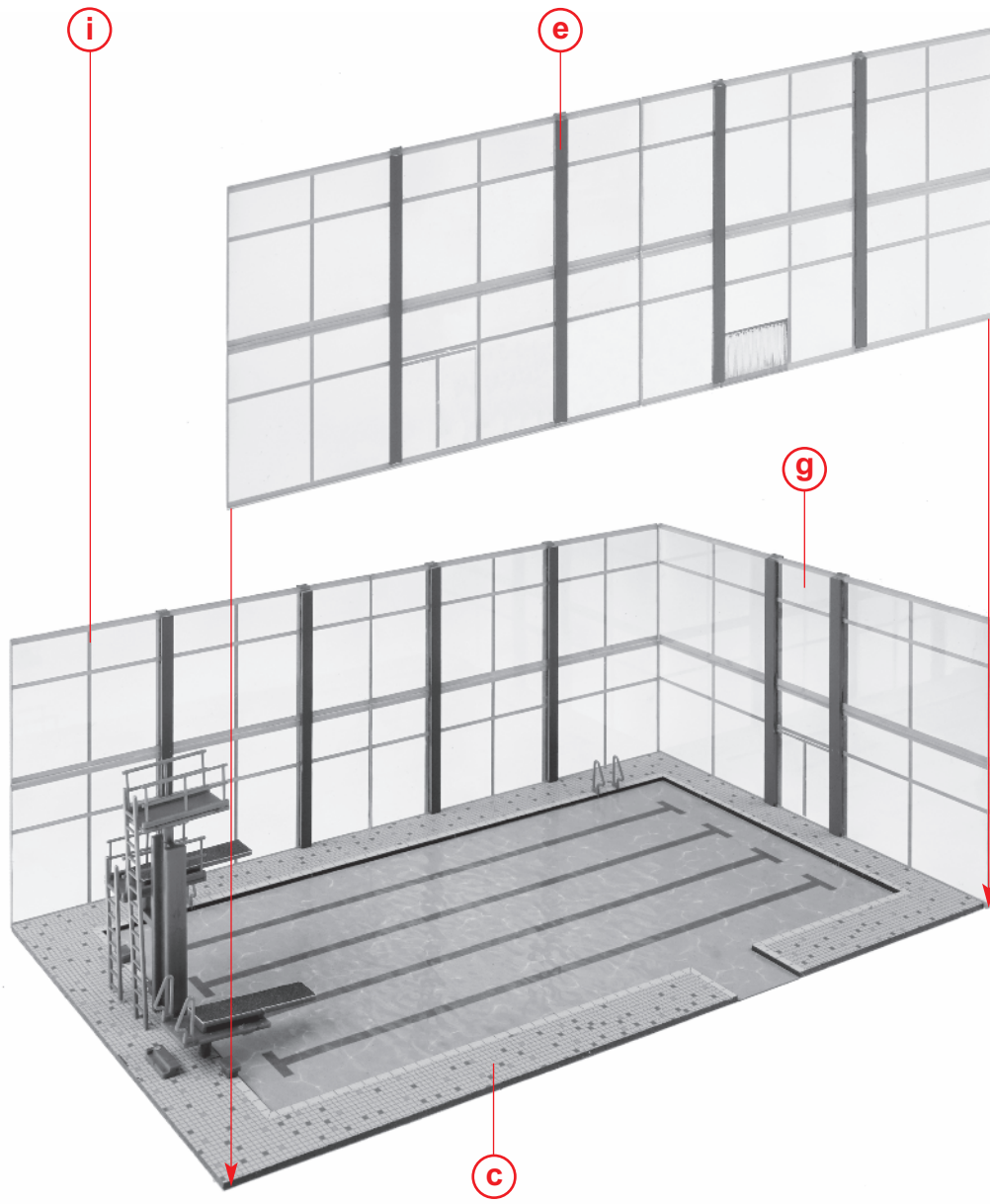

j

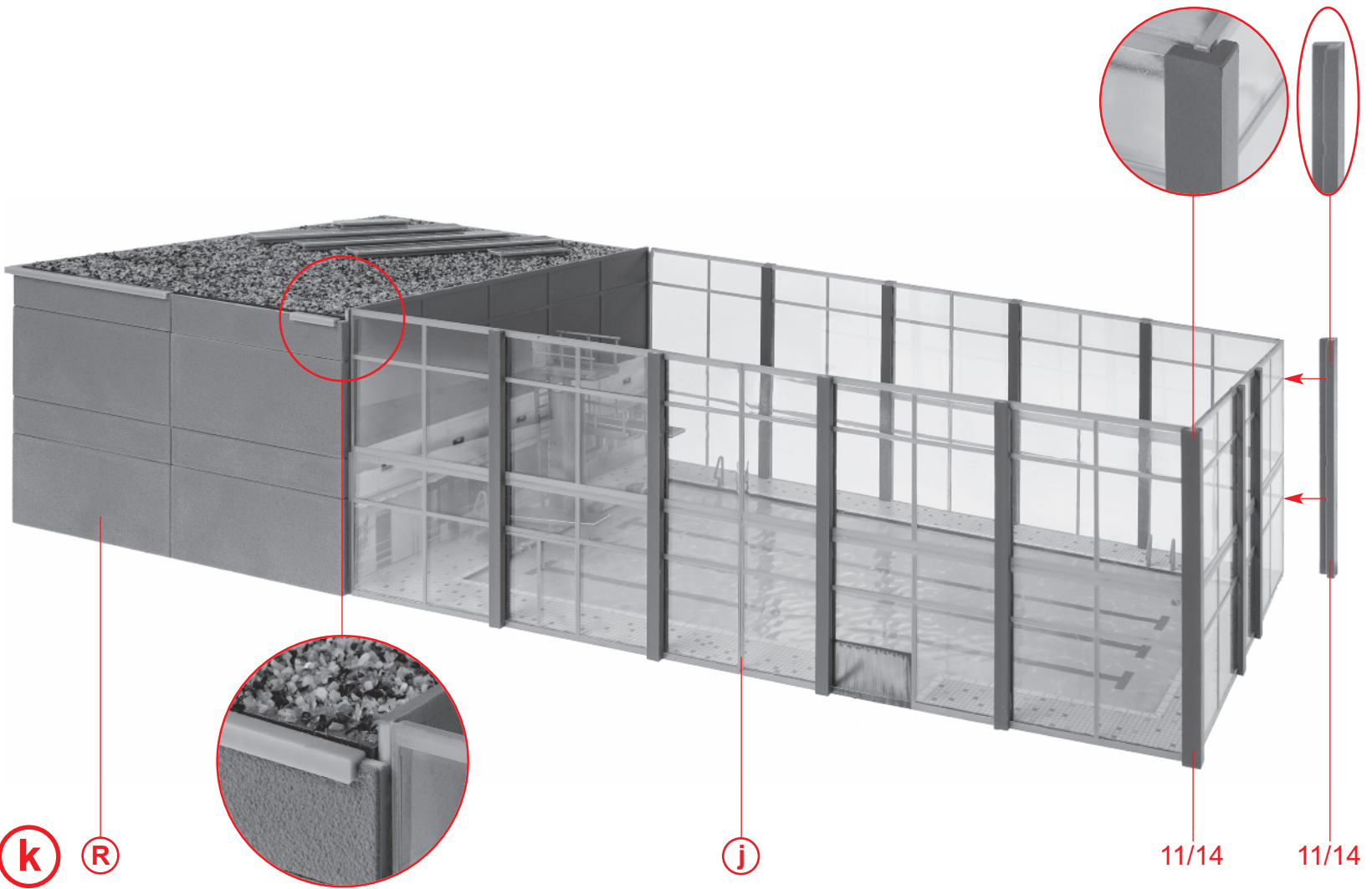

k

R

j

11/14

11/14



Lasercut-Kleber verw.
Use Lasercut glue.
Utilisez la colle Lasercut.
Gebruik Lasercutlijm.

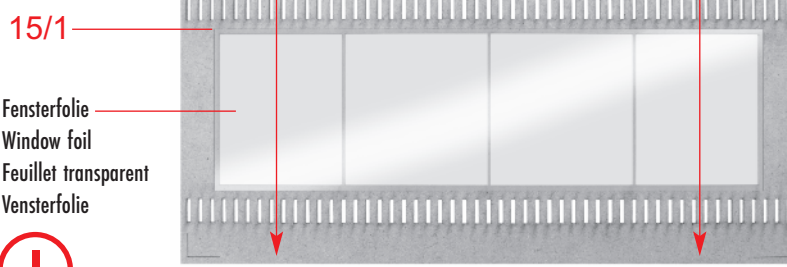

Fensterfolie
Window foil
Feuillet transparent
Vensterfolie

I

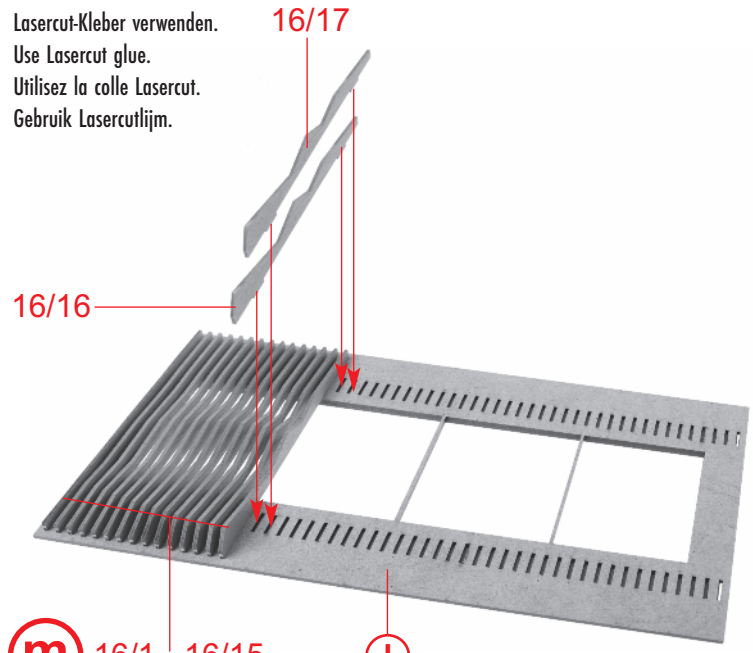

Lasercut-Kleber verwenden.
Use Lasercut glue.
Utilisez la colle Lasercut.
Gebruik Lasercutlijm.

m 16/1 - 16/15

I

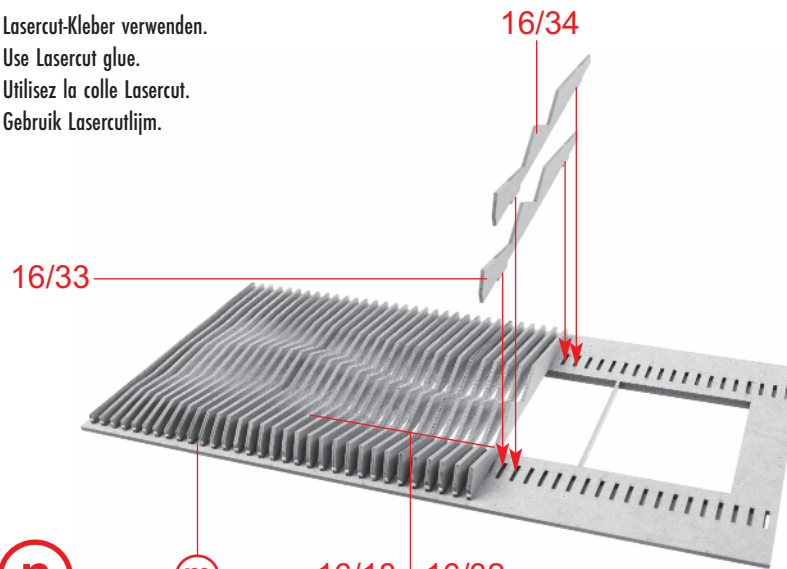

Lasercut-Kleber verwenden.
Use Lasercut glue.
Utilisez la colle Lasercut.
Gebruik Lasercutlijm.

n

m

16/18 - 16/32

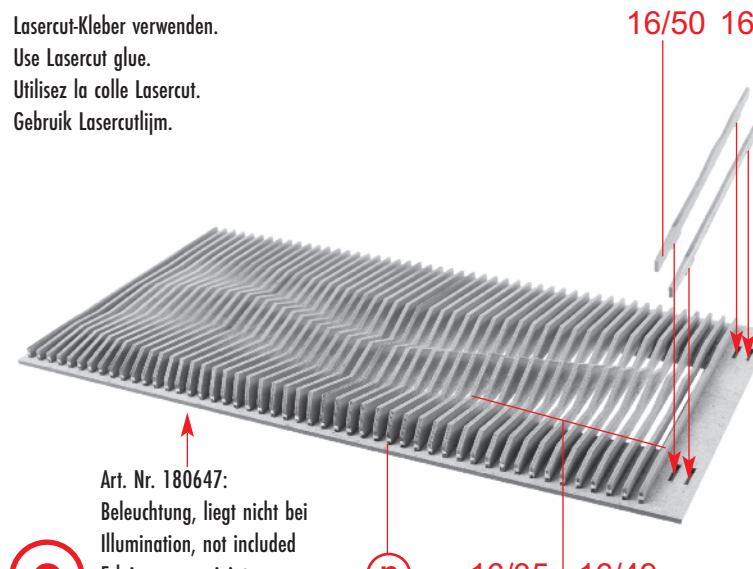

Lasercut-Kleber verwenden.
Use Lasercut glue.
Utilisez la colle Lasercut.
Gebruik Lasercutlijm.

o

n

16/35 - 16/49

Art. Nr. 180647:
Beleuchtung, liegt nicht bei
Illumination, not included
Eclairage, non jointe
Verlichting, niet bijgevoegd

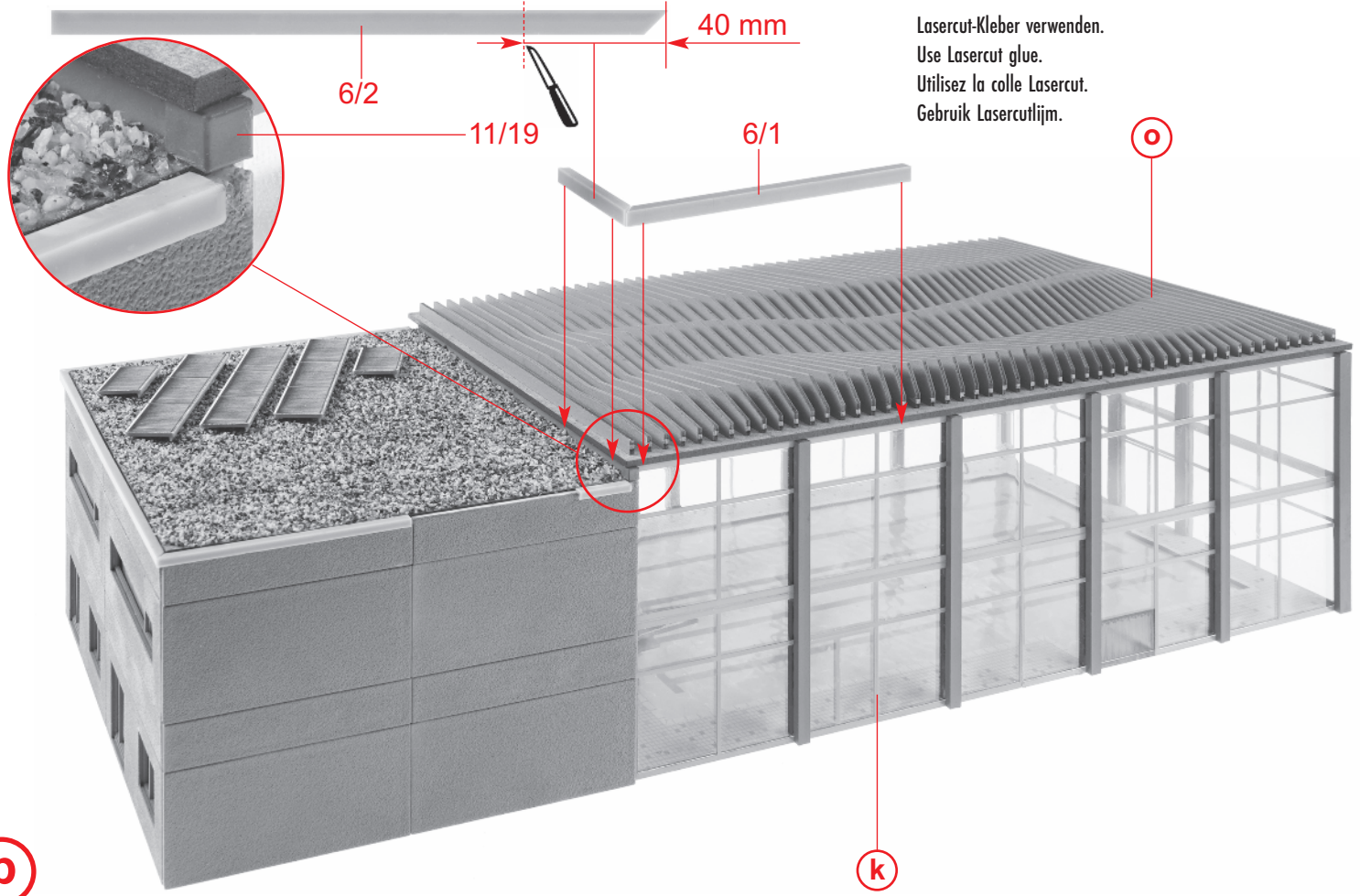

Lasercut-Kleber verwenden.
Use Lasercut glue.
Utilisez la colle Lasercut.
Gebruik Lasercutlijm.

p

k

o

10

Lasercut-Kleber verwenden.
Use Lasercut glue.
Utilisez la colle Lasercut.
Gebruik Lasercutlijm.

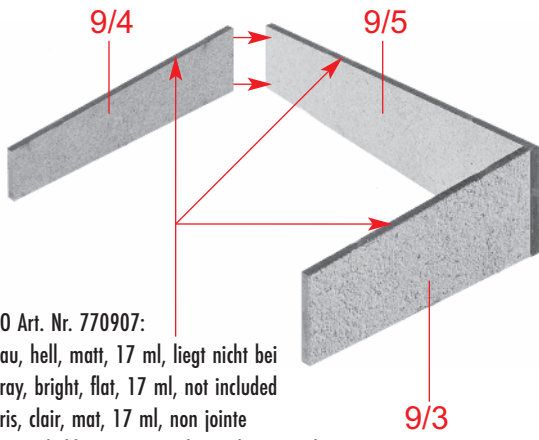

VALLEJO Art. Nr. 770907:
 Blaugrau, hell, matt, 17 ml, liegt nicht bei
 Blue gray, bright, flat, 17 ml, not included
 Bleu gris, clair, mat, 17 ml, non jointe
 Blauw grijs, helder, mat, 17 ml, niet bijgevoegd

q

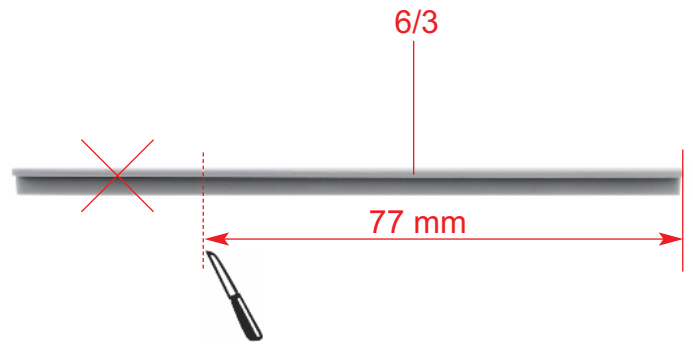

r 2 x

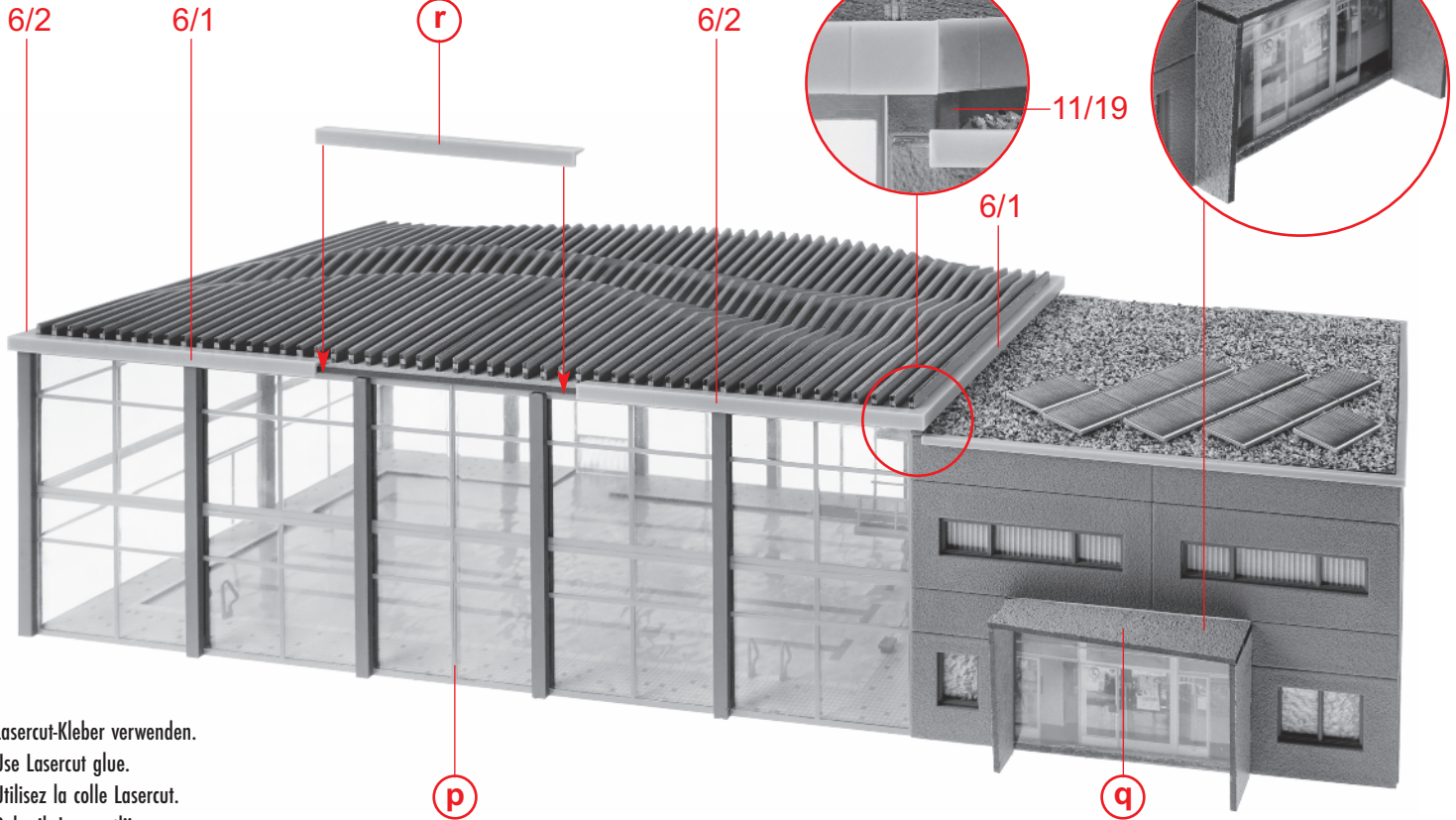

Lasercut-Kleber verwenden.
 Use Lasercut glue.
 Utilisez la colle Lasercut.
 Gebruik Lasercutlijm.

s

Lasercut-Kleber verwenden.
 Use Lasercut glue.
 Utilisez la colle Lasercut.
 Gebruik Lasercutlijm.

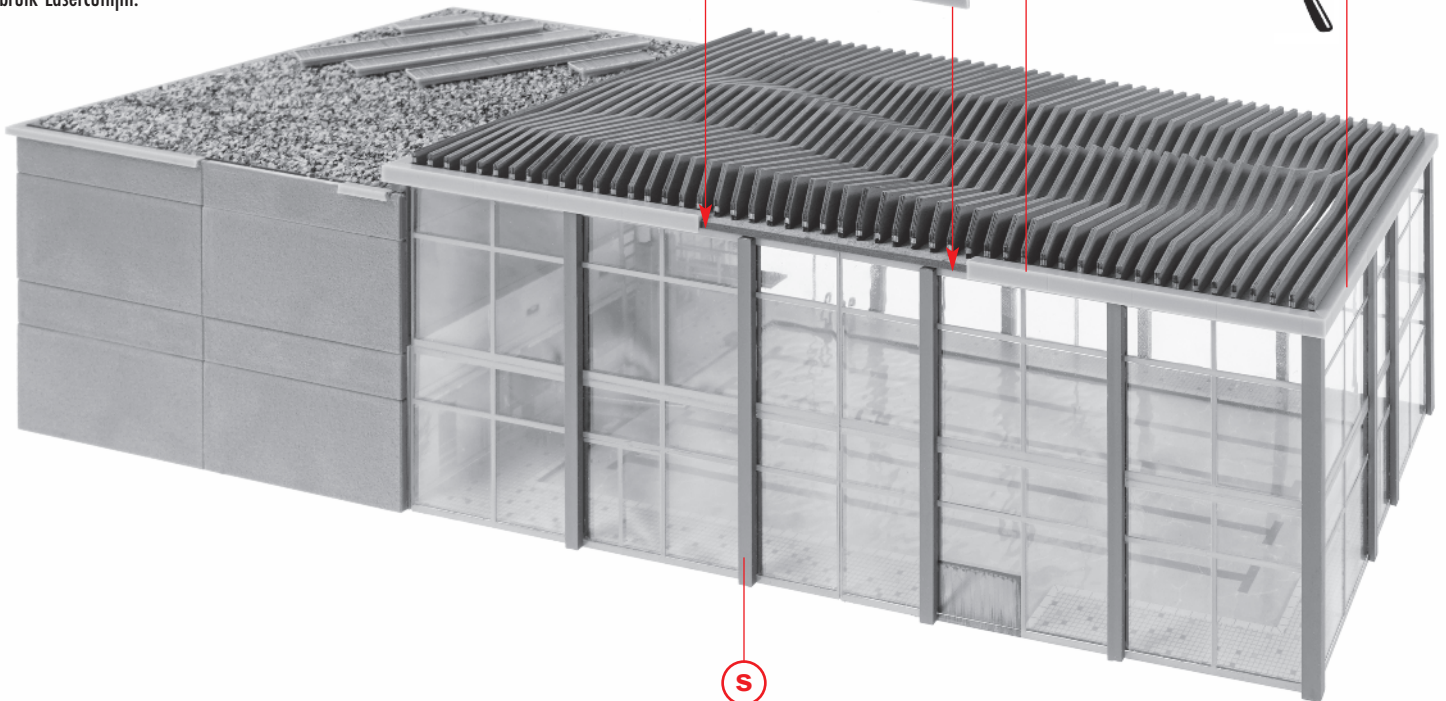
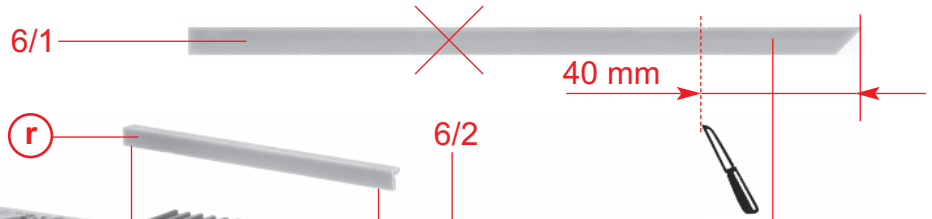

t

s

12/13
Fensterfolie
Window foil
Feuille transparent
Vensterfolie

rot red rouge rood

U 1/3 M 3/8

7/4
Deco 4

V Glatte Seiten
Pages lisses ! Smooth surface
Glatte zijde

7/4 7/3

Rahmen vorne
Frame in front
Cadre devant
Frame vooraan

Nur wenig Kleber verwenden!
Use only a little glue!
Utilisez seulement un peu de colle!
Gebruik slechts een beetje lijm!

W

12/9
rot red rouge rood

X 12/10

13/2
Deco 3

Wasserfolie
Water folie
Feuille d'eau
Waterfolie

Y

13/2
Deco 3

nicht kleben
do not glue
ne pas coller
niet lijmen

Z

1/17
1/4 G

A

1/4 G

B

12/12 1/17 1/4 G

rot red rouge rood

C

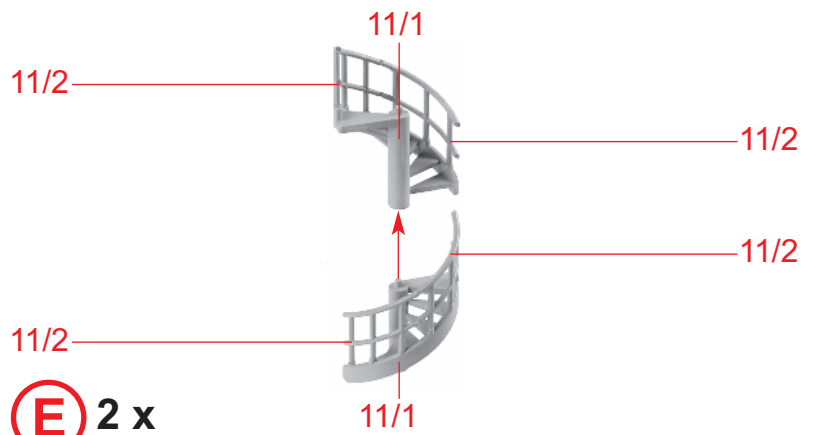
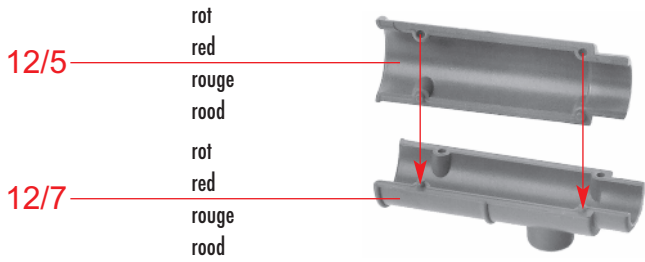

(D)

(E) 2 x

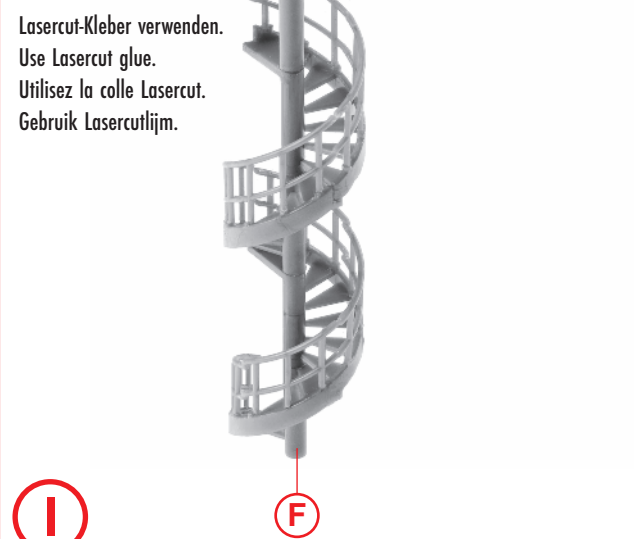
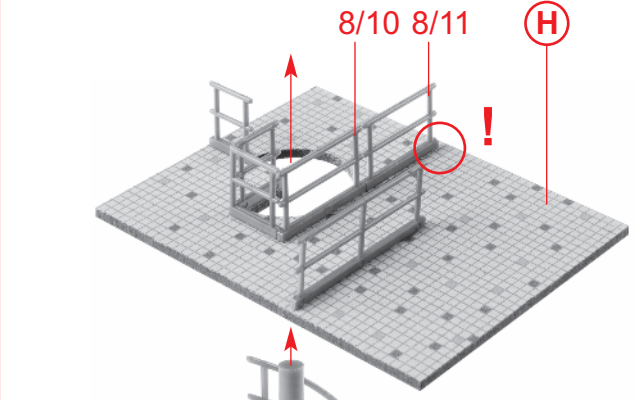
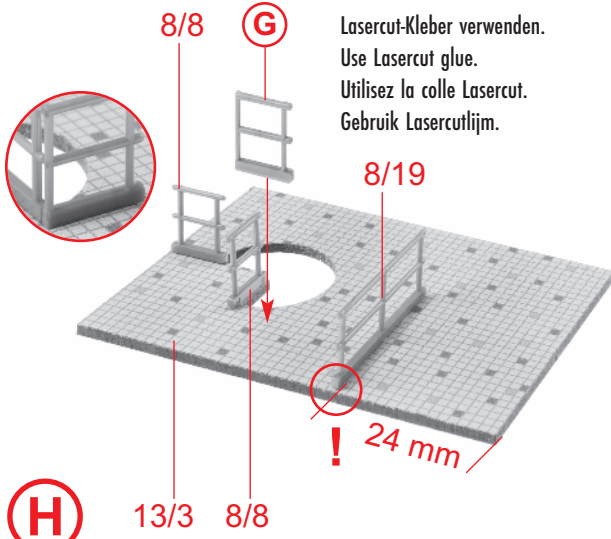
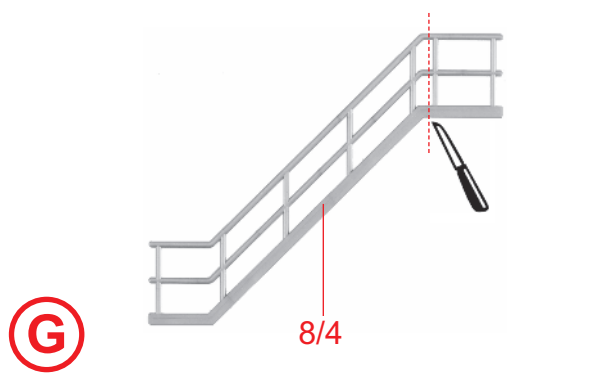
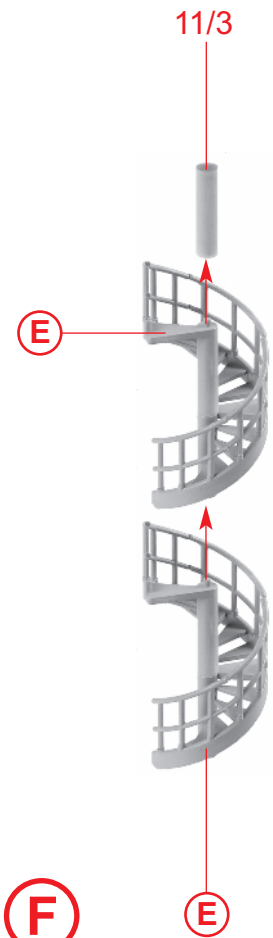

(F)

(H)

(I)

(F)

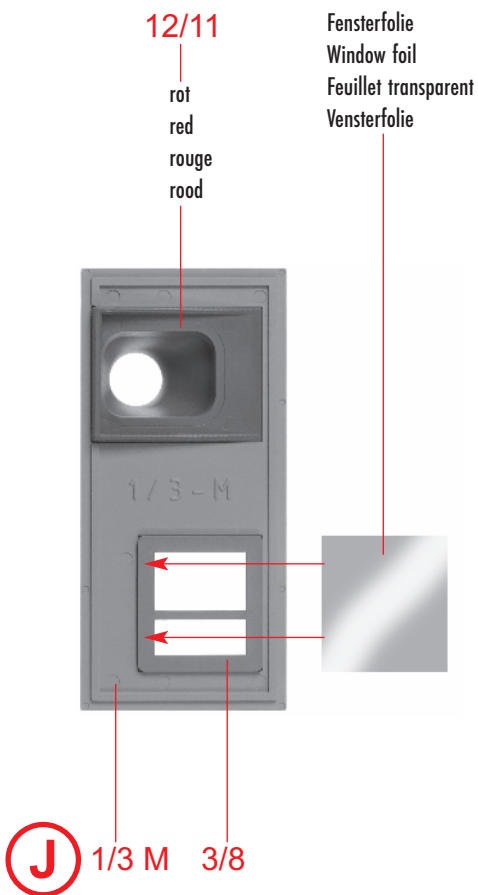

(J) 1/3 M 3/8



(K) w

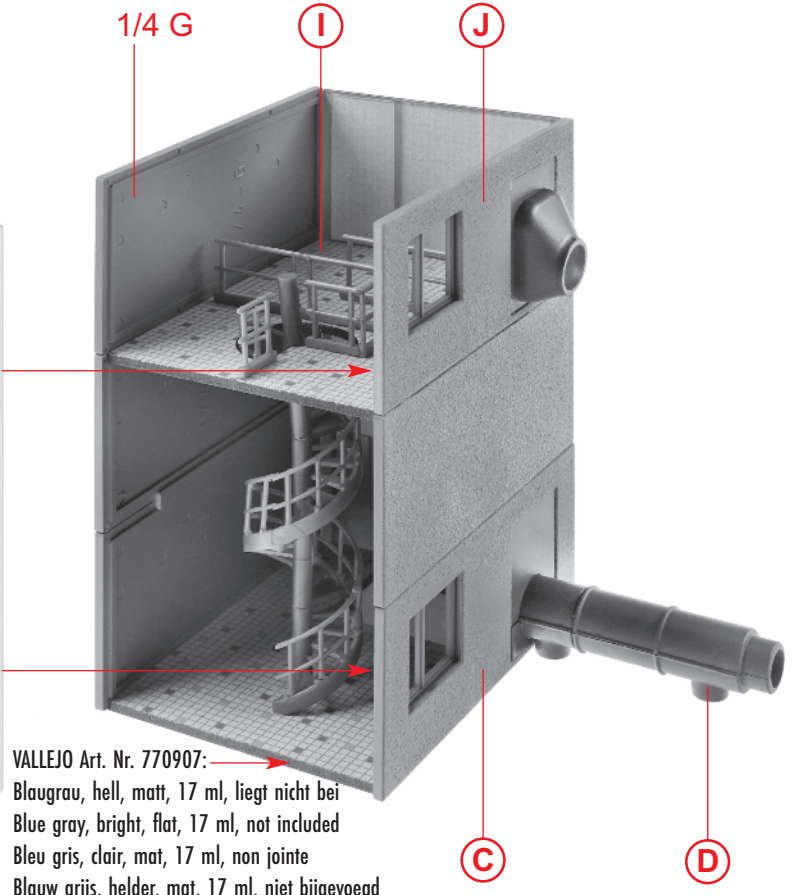

VALLEJO Art. Nr. 770907:
 Blaugrau, hell, matt, 17 ml, liegt nicht bei
 Blue gray, bright, flat, 17 ml, not included
 Bleu gris, clair, mat, 17 ml, non jointe
 Blauw grijs, helder, mat, 17 ml, niet bijgevoegd

(C)

(D)

12/22

9/1

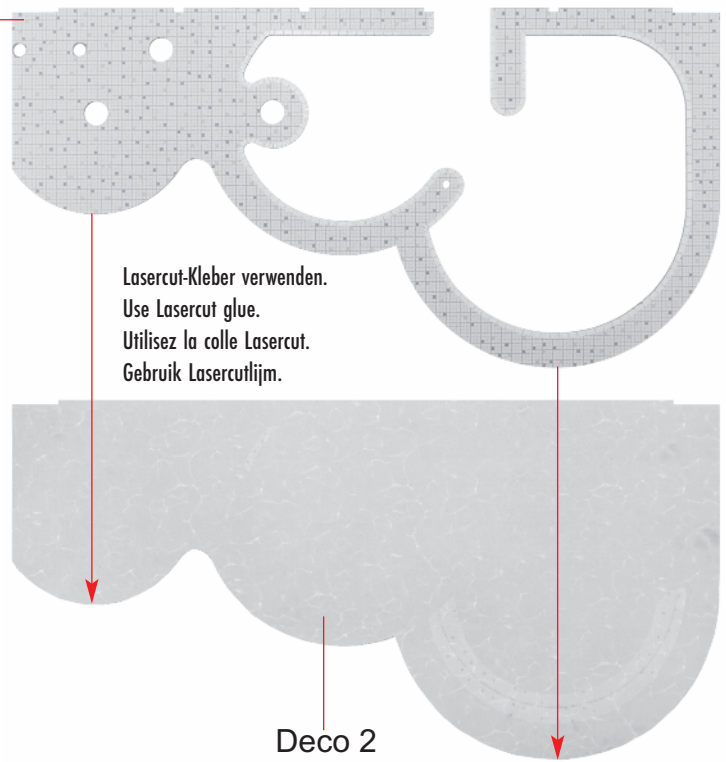
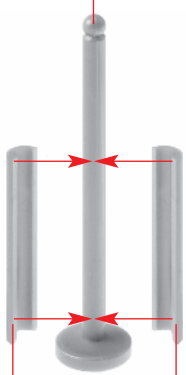

Lasercut-Kleber verwenden.
Use Lasercut glue.
Utilisez la colle Lasercut.
Gebruik Lasercutlijm.

Deco 2

L 2 x 12/27 12/27

M

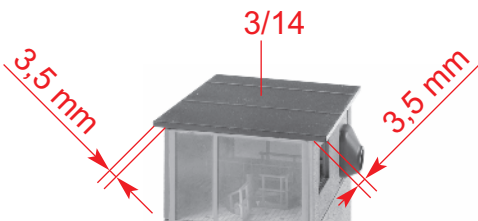

Wasserfolie
Water folie
Feuille d'eau
Waterfolie

Lasercut-Kleber verwenden.
Use Lasercut glue.
Utilisez la colle Lasercut.
Gebruik Lasercutlijm.

N

K

M

Mit Alleskleber kleben.
Use all-purpose glue.
Utiliser de la colle universelle.
Met een universele lijm lijmen.

12/23

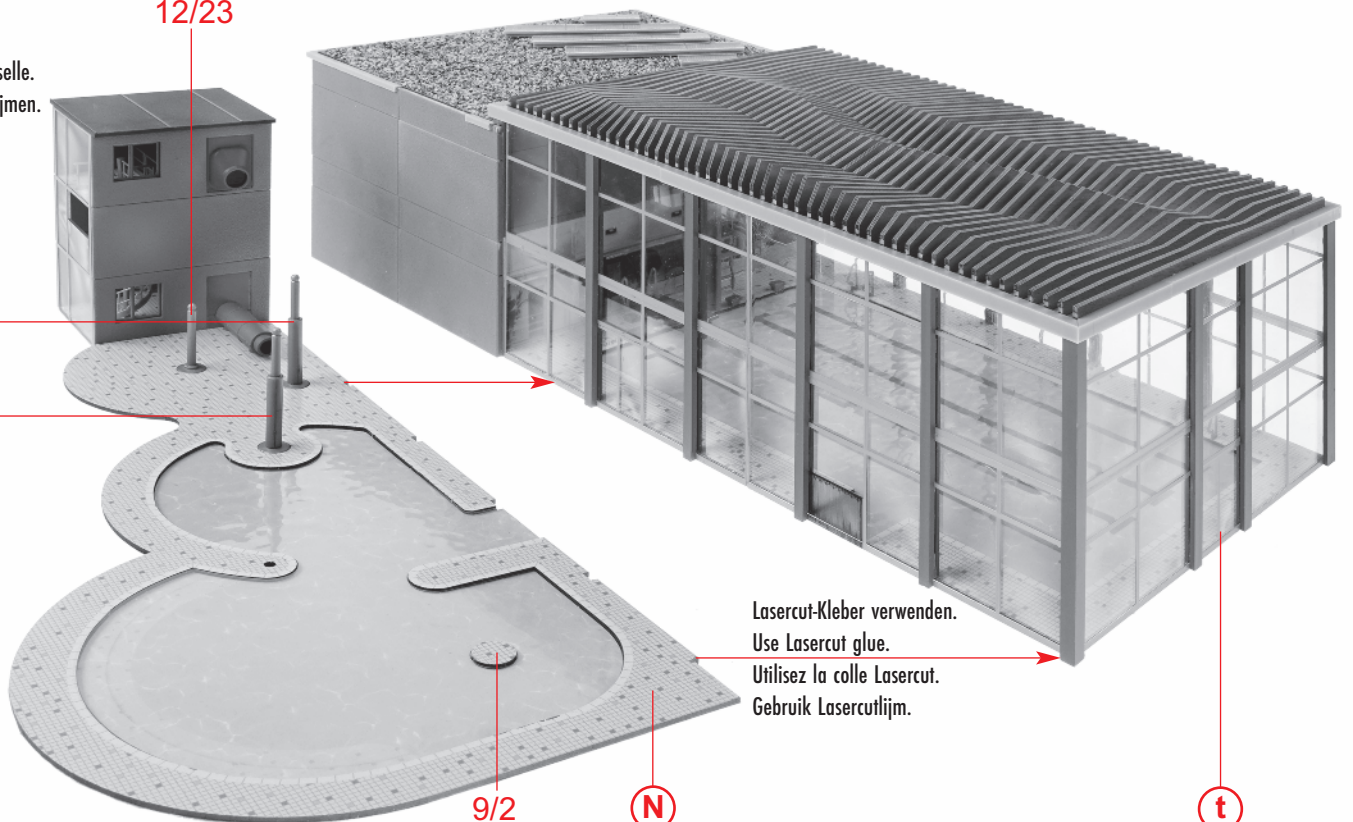

Lasercut-Kleber verwenden.
Use Lasercut glue.
Utilisez la colle Lasercut.
Gebruik Lasercutlijm.

O

9/2

N

t

noch nicht kleben
do not glue yet
ne colle pas encore
nog niet lijmen

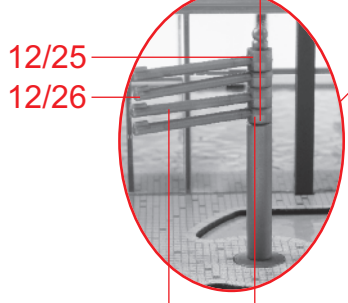
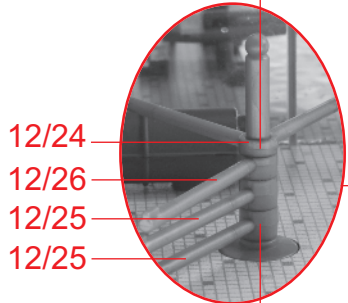
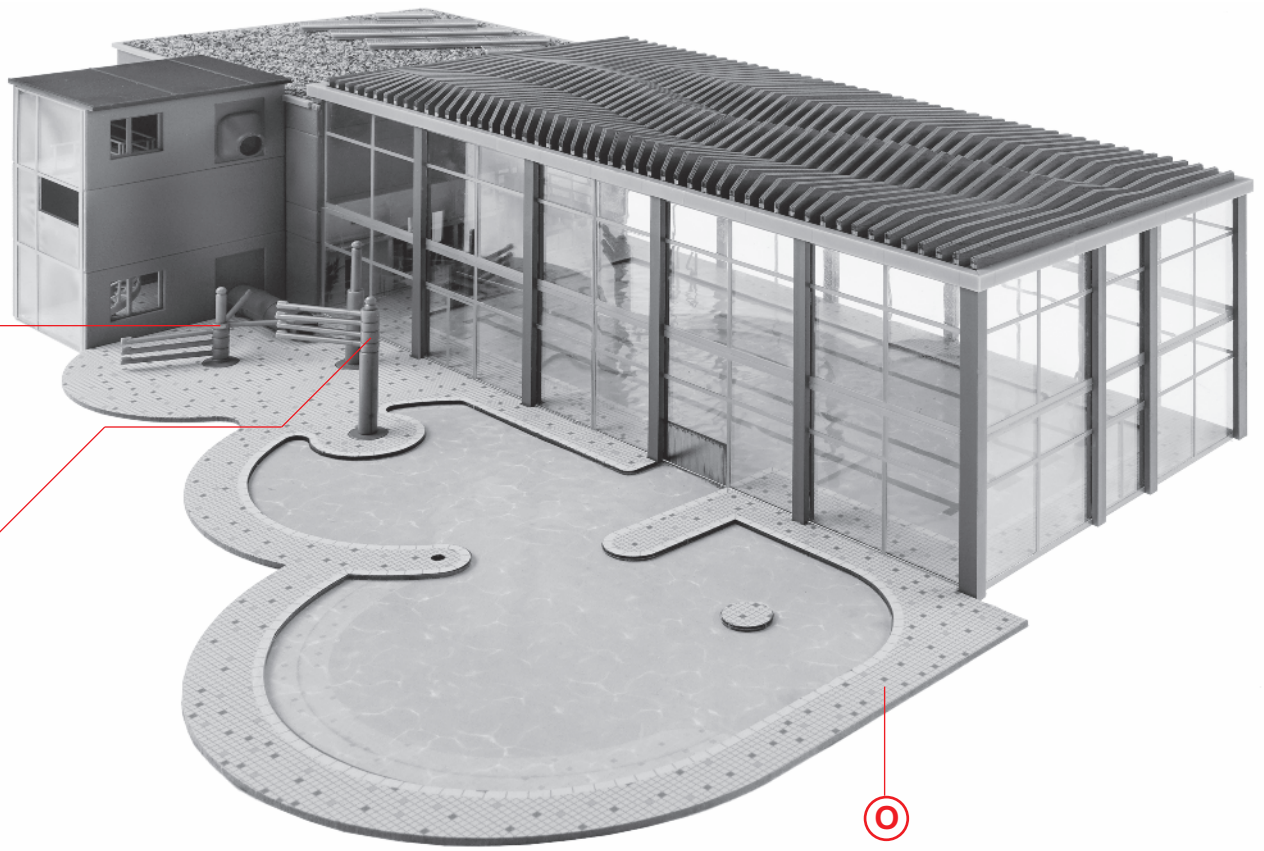

P 12/25 12/26

O

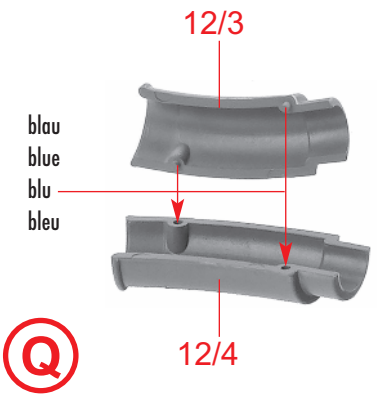

Q

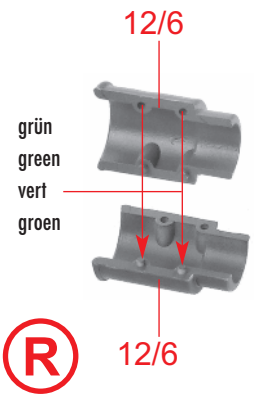

R

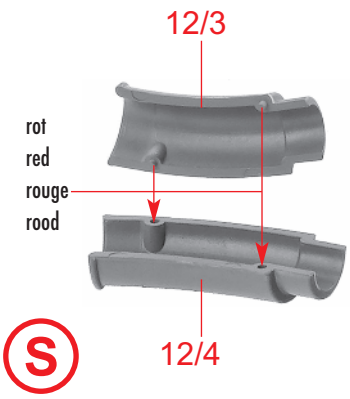

S

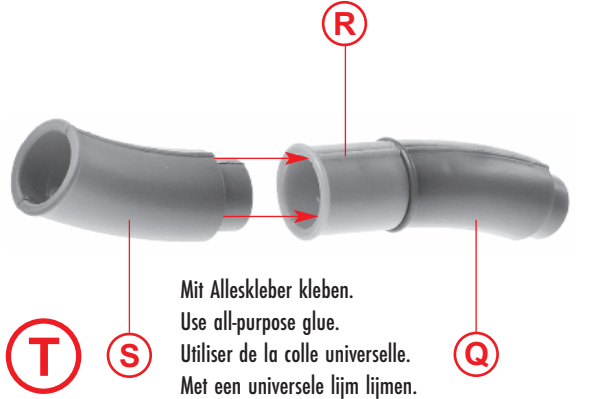

T

Mit Alleskleber kleben.
Use all-purpose glue.
Utiliser de la colle universelle.
Met een universele lijm lijmen.

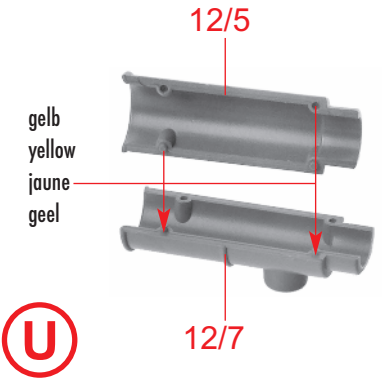

U

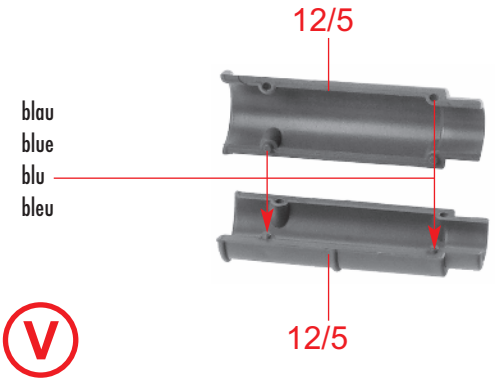

V

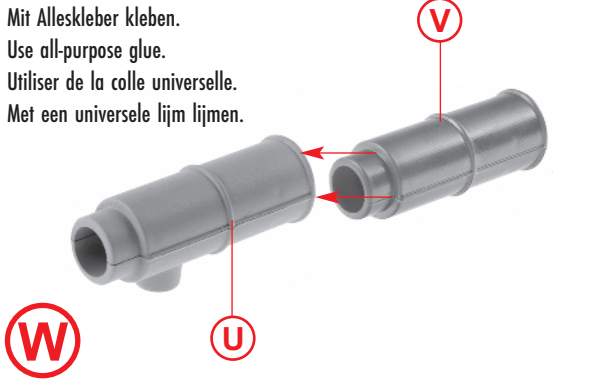

W

Mit Alleskleber kleben.
Use all-purpose glue.
Utiliser de la colle universelle.
Met een universele lijm lijmen.

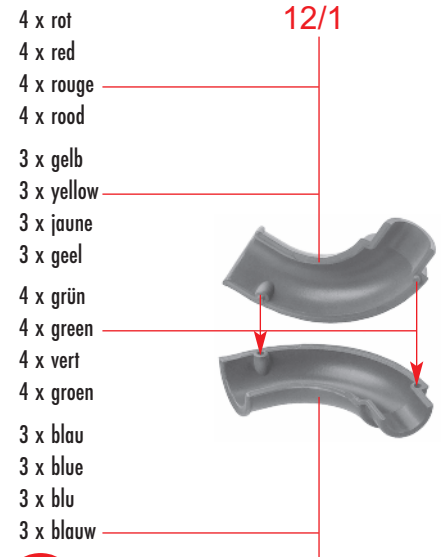

X 14 x 12/2

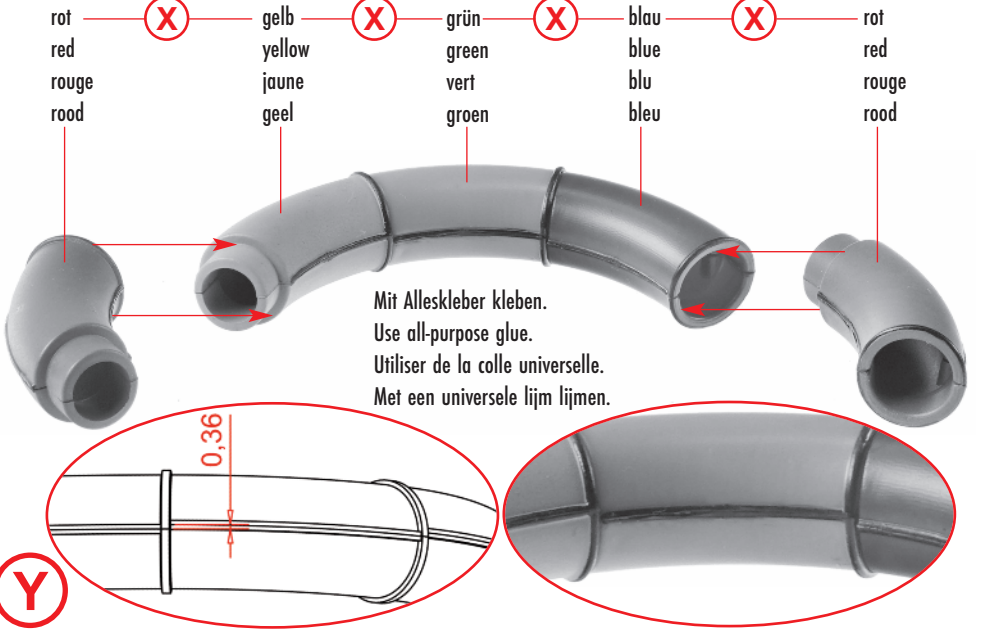

Y

Mit Alleskleber kleben.
Use all-purpose glue.
Utiliser de la colle universelle.
Met een universele lijm lijmen.

0,36

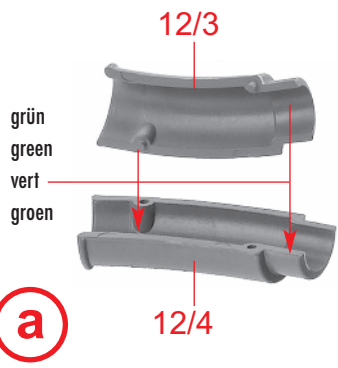

grün
green
vert

a

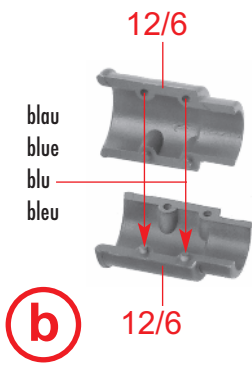

blau
blue
bleu

b

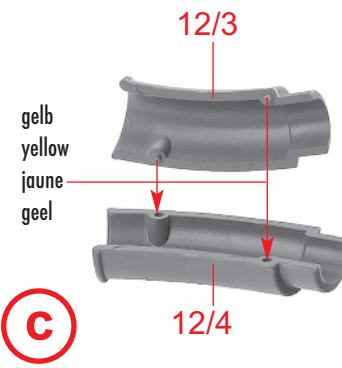

gelb
yellow
jaune

c

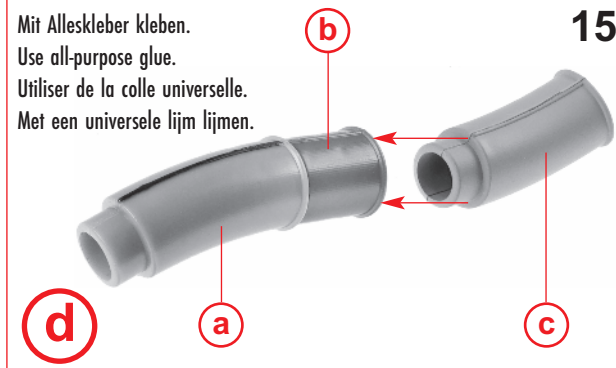

rot
red
rouge

d

Mit Alleskleber kleben.
Use all-purpose glue.
Utiliser de la colle universelle.
Met een universele lijm lijmen.

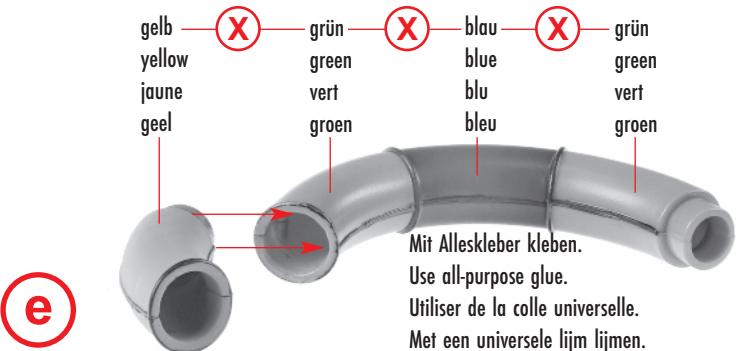

e

Mit Alleskleber kleben.
Use all-purpose glue.
Utiliser de la colle universelle.
Met een universele lijm lijmen.

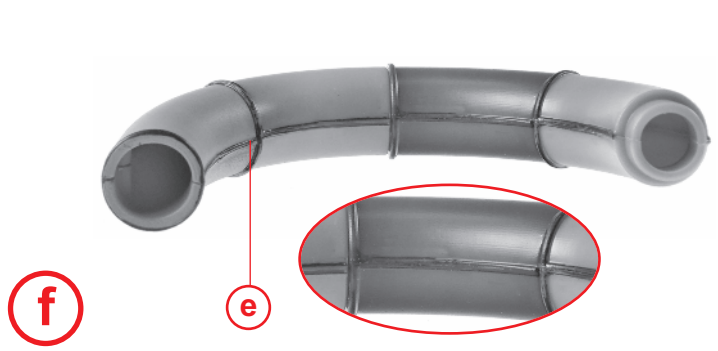

f

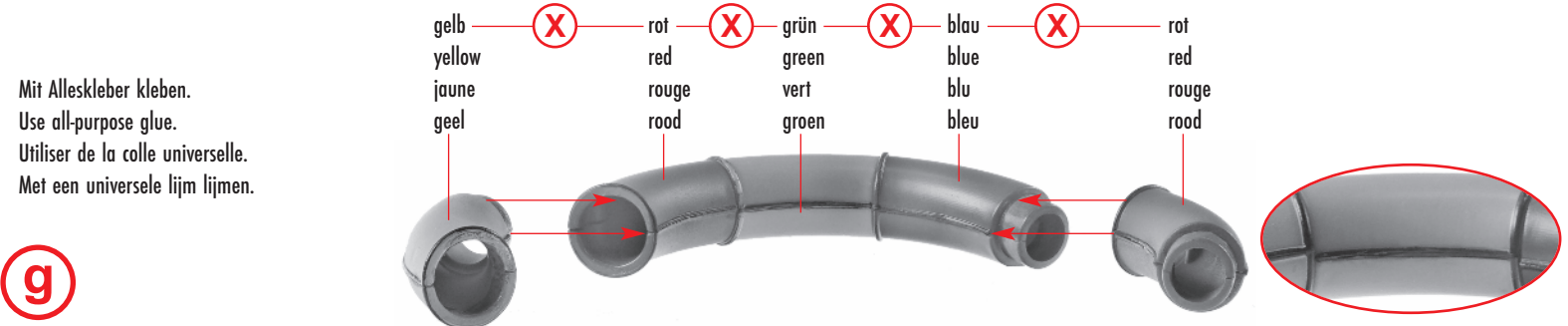

g

Mit Alleskleber kleben.
Use all-purpose glue.
Utiliser de la colle universelle.
Met een universele lijm lijmen.



h

g

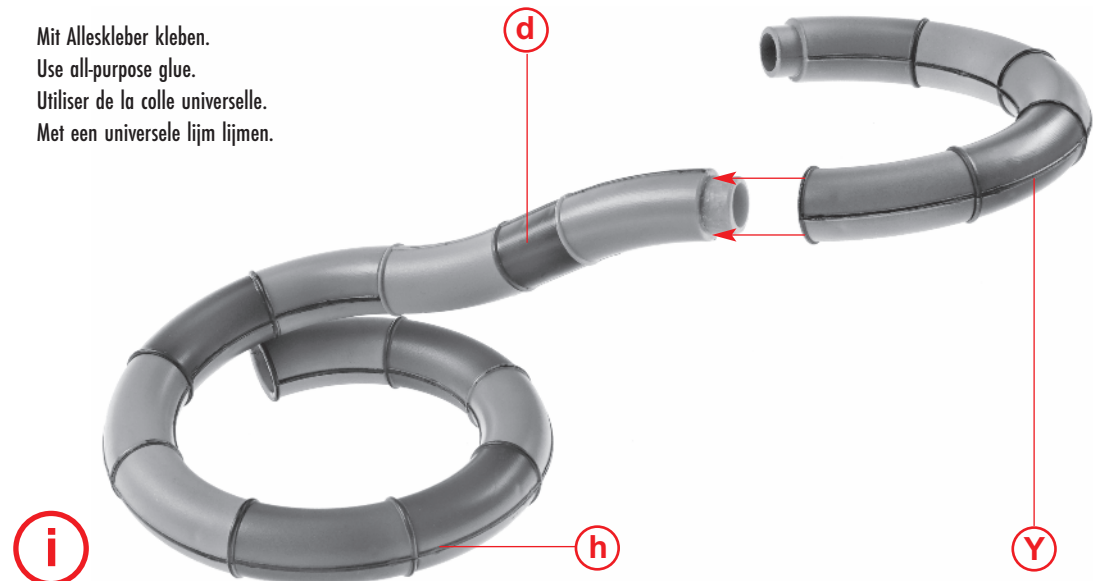

i

d

Y

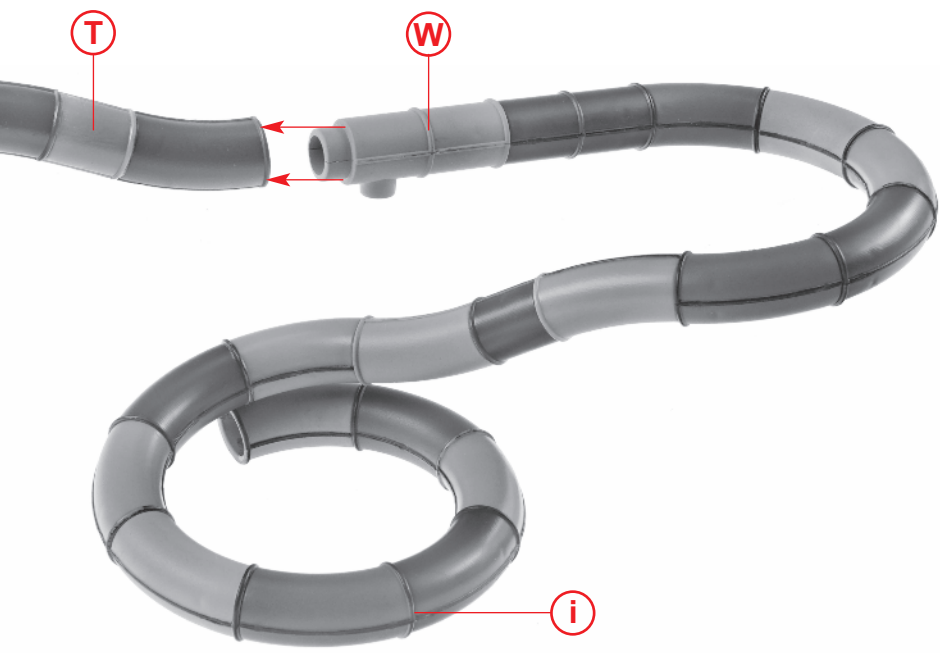

j

i

Mit Alleskleber kleben.
Use all-purpose glue.
Utiliser de la colle universelle.
Met een universele lijm lijmen.

16

Die Auflagen der Stützen so lange drehen, bis die Rutsche komplett aufliegt. Erst dann die Stützen und die Rutsche festkleben.

Rotate the rests of the supports until the slide is completely supported. Only then should the supports and the slide be glued.

Faire tourner les appuis des supports jusqu'à ce que le toboggan repose complètement. Seulement après, coller les supports et le toboggan.

De stangen van de steunen net zolang draaien totdat de glijbaan volledig erop ligt. Pas dan de steunen en de glijbaan vastlijmen.

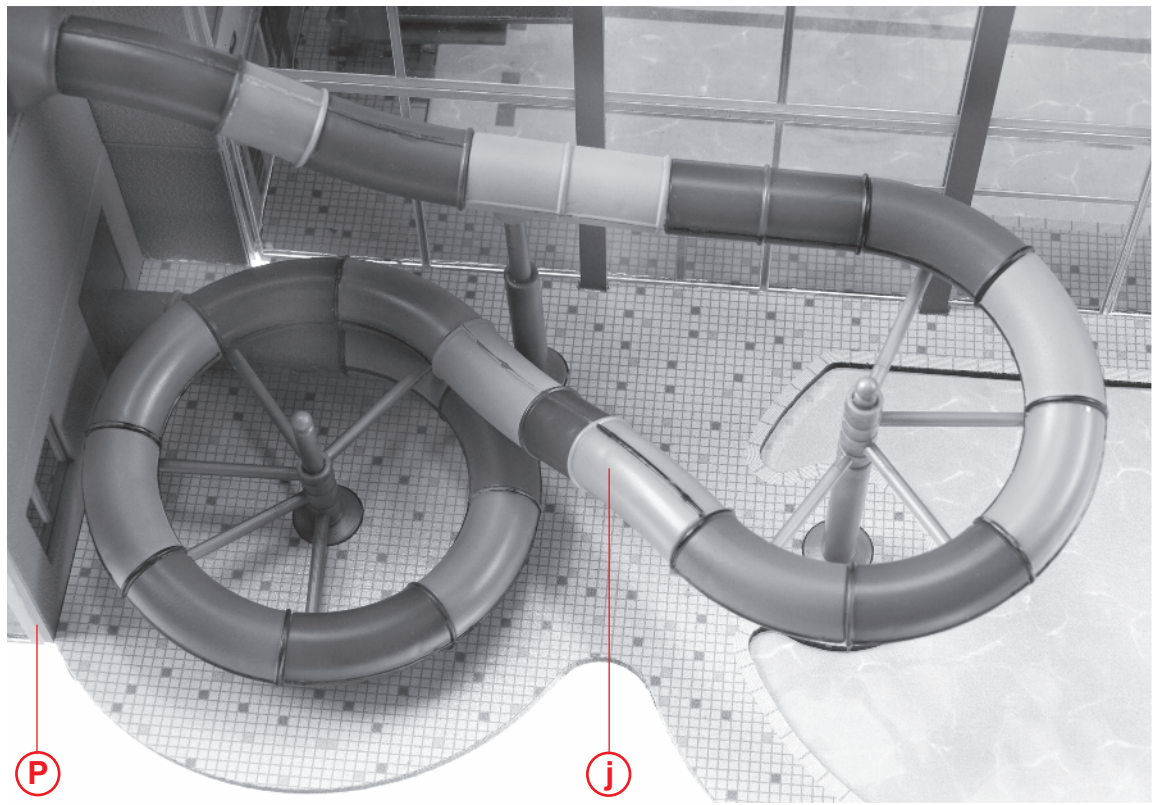

k

P

j

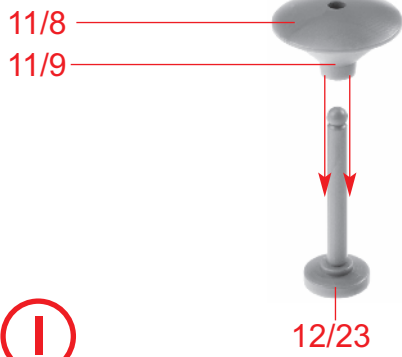

l

12/23

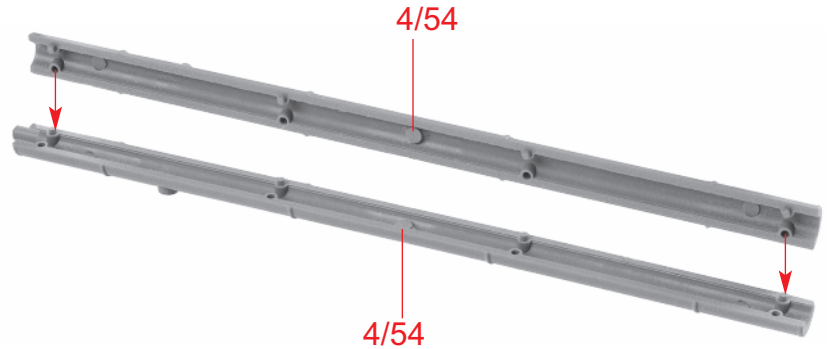

m 2 x

4/54

4/54

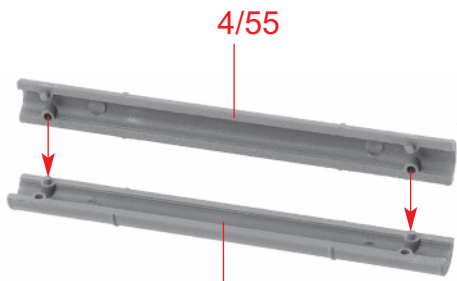

n 2 x

4/55

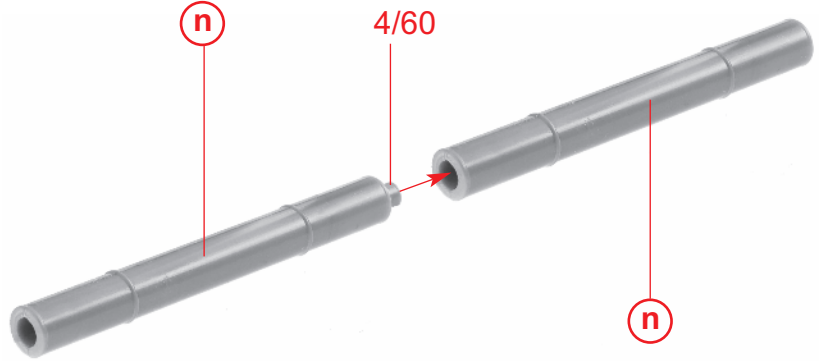

o

n

4/60

n

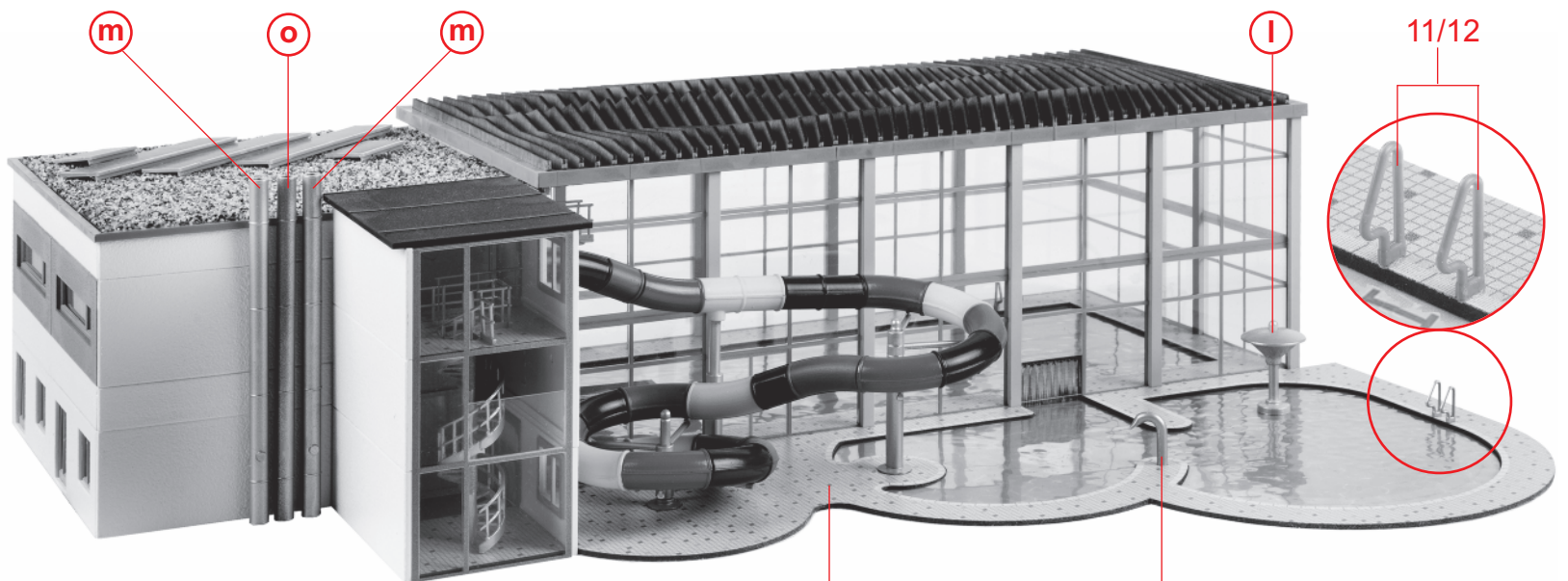

p

k

11/10

11/12