

# DESIGN-PLATTENBAU NACH CARSTEN KRUSE



PREFABRICATED HIGH-RISE DESIGNED BY CARSTEN KRUSE

HLM EN PRÉFABRIQUÉ DESIGN SELON CARSTEN KRUSE

DESIGN-PLATTENBAU VOLGENS CARSTEN KRUSE

Art. Nr. 130800

**D**

Vor Beginn des Bastelns sollten Sie sich mit den Spritzlingen und der Anleitung vertraut machen. Sollte es einmal vorkommen, dass ein Teil im Bausatz fehlt, kreuzen Sie bitte das fehlende Teil in der Anleitung an und schicken Sie diese bitte an Fa. Gebr. FALLER GmbH, Abt. Kundendienst, kundendienst@faller.de, Kreuzstraße 9, 78148 Gütenbach. Sie erhalten dann umgehend Ersatz. Es kann vorkommen, dass bei einem Bausatz Einzelteile übrig sind.

**GB**

Before beginning with the assembly please familiarize yourself with the parts and read the instructions carefully. In case of missing parts please indicate these on the instructions leaflet with a circle and return the leaflet to Gebr. FALLER GmbH, kundendienst@faller.de, Kreuzstraße 9, D-78148 Gütenbach, Germany. You will receive the replacement by return. It may happen in a kit that some parts are not required.

**F**

Avant de commencer le montage de votre maquette bien lire la notice et repérer les grappes. Si une pièce manque dans une boîte, cochez la pièce correspondante sur la notice et renvoyez-la-nous à Gebr. FALLER GmbH, kundendienst@faller.de, Kreuzstraße 9, D-78148 Gütenbach (R.F.A.). Nous vous ferons parvenir la pièce par retour. Dans certains kits, il est possible que certaines pièces ne soient pas utilisées.

**NL**

Vóór het bouwen zou men de gietstukken en de handleiding moeten bestuderen. Indien onverhoopt een onderdeel aan het bouwpakket ontbreekt, gelieve men het ontbrekende deel in de handleiding aan te kruisen en deze te zenden aan Gebr. FALLER GmbH, kundendienst@faller.de, Kreuzstraße 9, D-78148 Gütenbach. U ontvangt dan omgaand en gratis het ontbrekende onderdeel. Het kan voorkomen dat u bij bepaalde bouwdozen onderdelen overhoudt.

Für den Zusammenbau des Modells empfehlen wir folgende FALLER-Artikel (sind nicht im Bausatz enthalten):  
For the assembly of the kit we recommend following FALLER products (not included in the kit):  
Pour l'assemblage du modèle, nous vous recommandons les articles FALLER suivants (non inclus dans le kit):  
Om dit model te bouwen adviseren wij de volgende FALLER producten (maken geen deel uit van deze bouwset):



Art. Nr. 170492  
FALLER-EXPERT

Flüssigkleber in Plastikflasche mit Spezialkanüle für feinste Klebstoffdosierung.

Liquid cement in plastic bottle with canule for very fine dosage.

Celle liquide en bouteille plastique avec bec verseur pour un dosage précis.

Vloeibare lijm in plastic-flescon met doseerbuisje om nauwkeurig te lijmen.



Art. Nr. 170688  
SPEZIAL-SEITENSCHNEIDER

zum geratlosen Abtrennen von feinsten Spitzteilen.  
Nur für Polystyrol geeignet.

Special side cutter for cutting off ultra-fine moulded parts without burrs. Only suitable for polystyrene.

Pince coupants spéciale pour couper sans bavure les pièces miniatures moulées par injection. Convient uniquement au polystyrène.

Speciale zijknijplang voor het braamloos afknippen van de fijnste gietstukdelen. Alleen geschikt voor polystyrol.

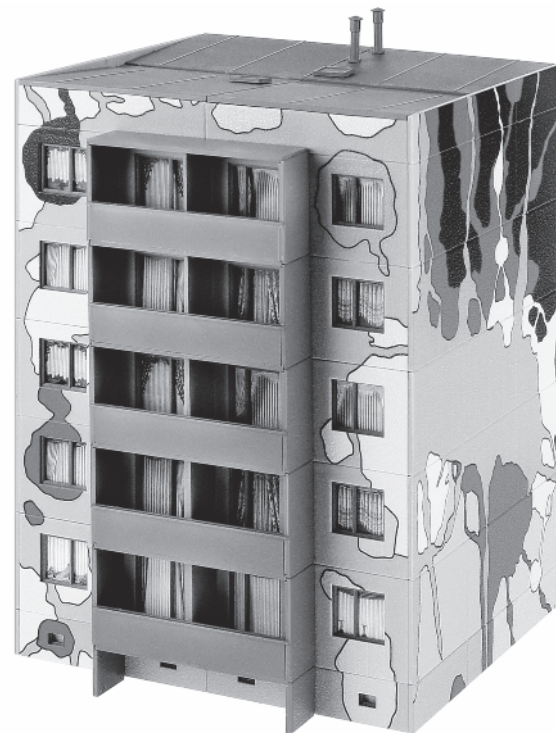

<b>Inhalt</b>	Spritzlinge	1 A	5 x	1 E	10 x	2 C	1 x	3 C	4 x
<b>Contents</b>	Sprues	1 B	5 x	2 A	1 x	3 A	3 x		
<b>Contenu</b>	Moulages	1 C	1 x	2 B	5 x	3 B	3 x		
<b>Inhoud</b>	Gietstukken								

Sa. Nr. 130 800 1

2

Fensterfolie

Die beiliegende Fensterfolie entsprechend der benötigten Größe ausschneiden und vorsichtig mit wenig Klebstoff auf die Rückseite der Fensterrahmen aufkleben.

Window foil

Cut the attached window foil according to the illustrations and glue it carefully with a little glue to the rear side of the window frames.

Feuillet transparent pour fenêtres

Découper le feuillet transparent pour fenêtres inclus d'après l'illustration.

Coller proprement avec un peu de colle sur la face arrière du cadre des fenêtres.

Vensterfolie

De meegeleverde vensterfolie conform de afbeeldingen uitknippen of uitsnijden en voorzichtig met een beetje lijm op de achterzijde van het raam plakken.

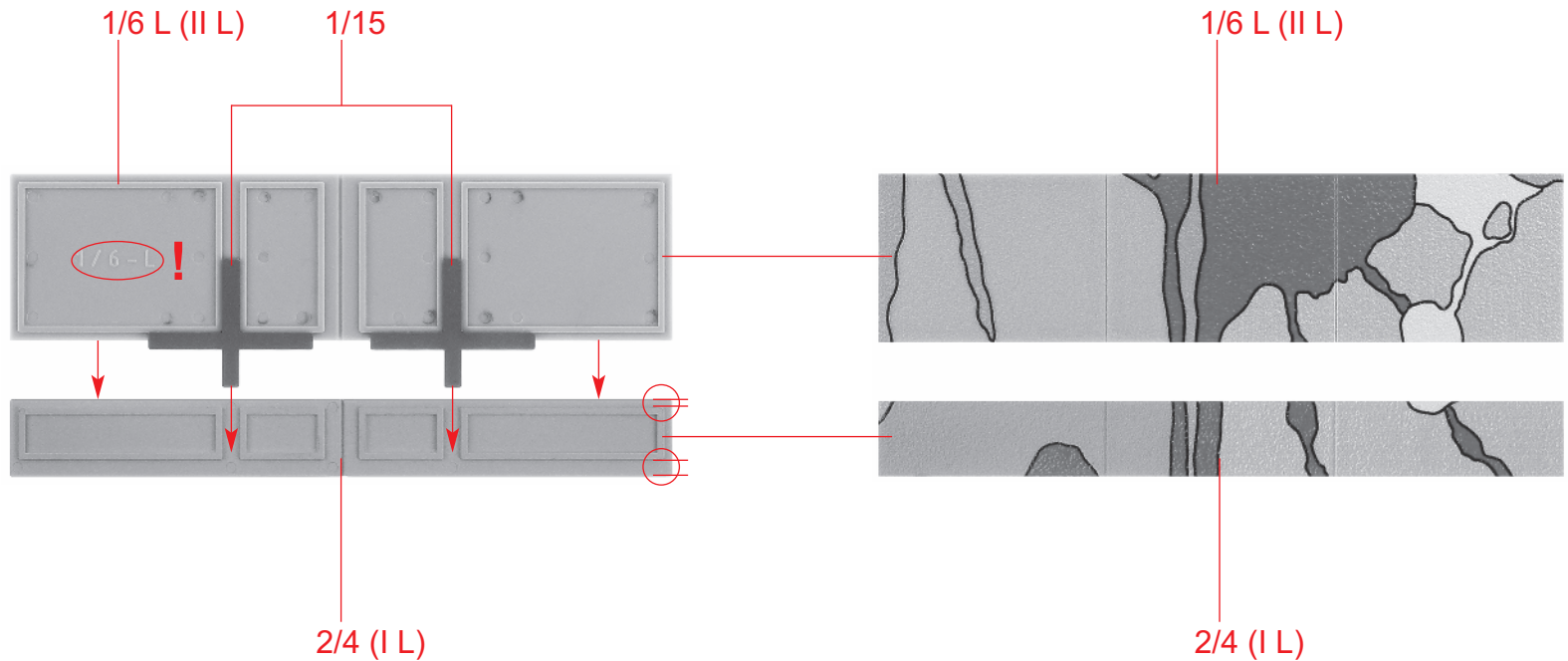

A

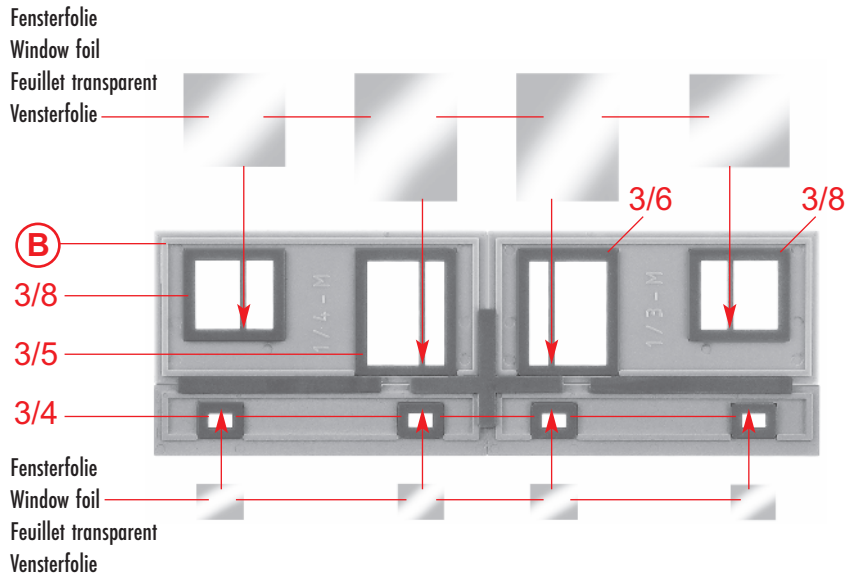
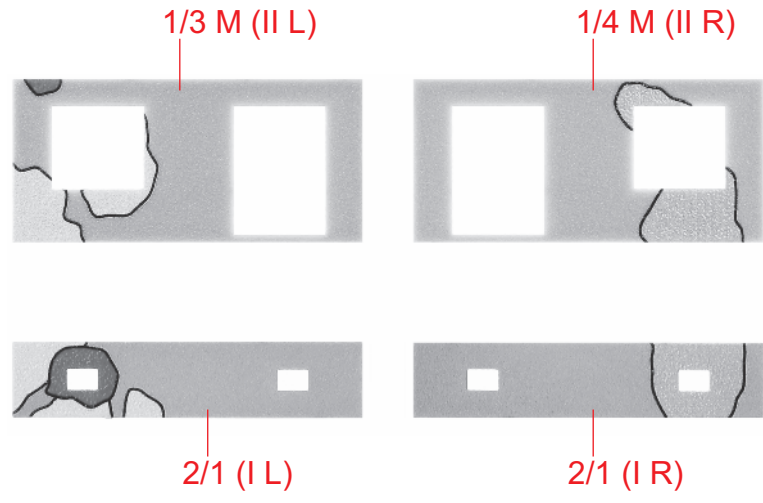
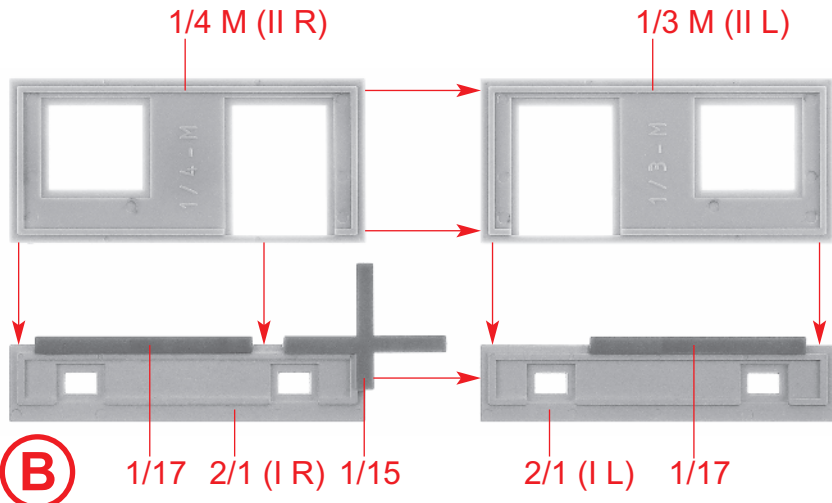

**C**

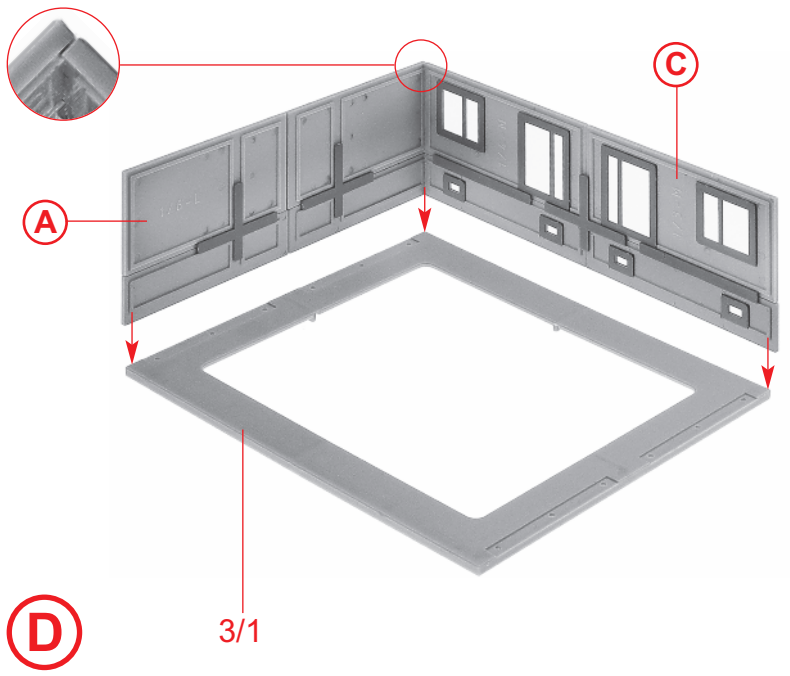

4

1/6 L (II R)

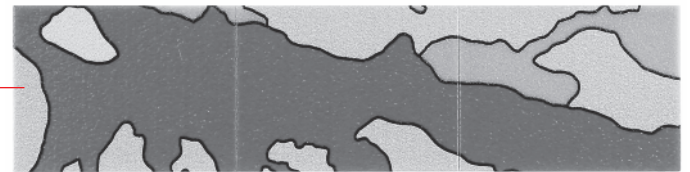

1/15

1/15

**E**

2/4 (I R)



1/2 X (II R)



1/17

1/16

**F**

2/1

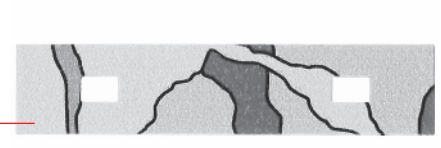

1/11



1/16

1/16

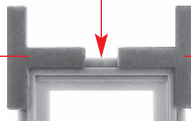

1/9

**G**

1/10



1/16

2/2

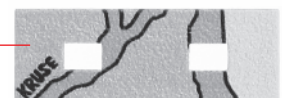

**H**

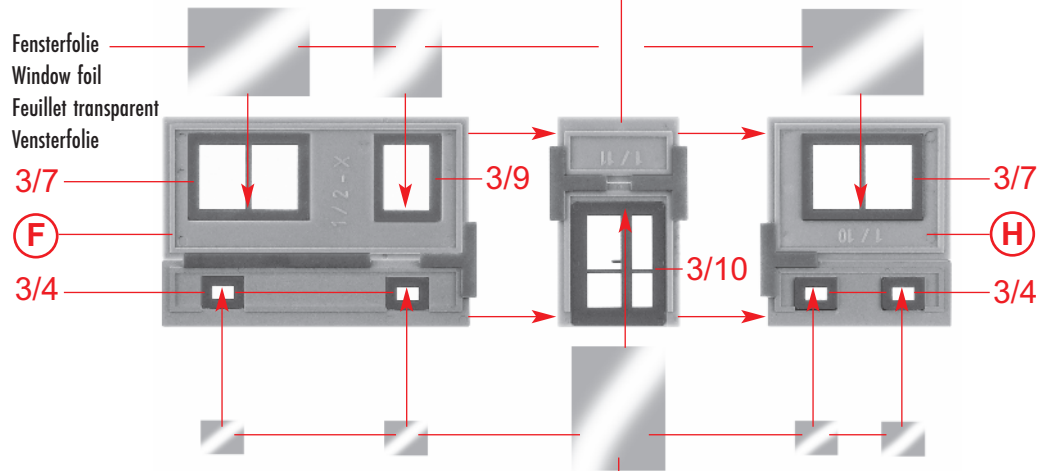

I

Fensterfolie  
 Window foil  
 Feuille transparent  
 Vensterfolie

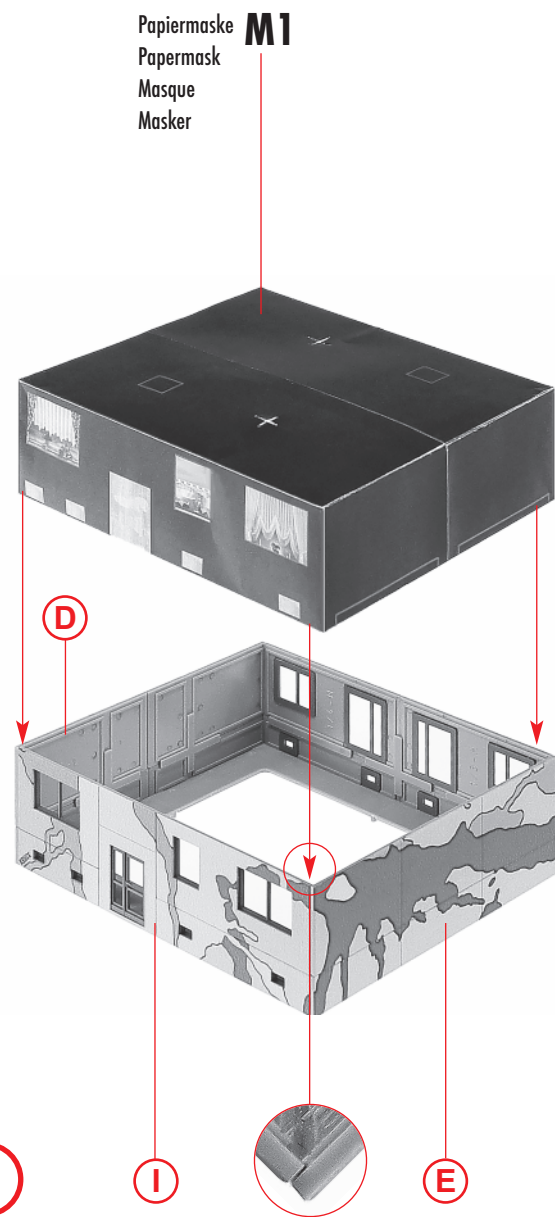

6

1/6 L (III L)

1/14

1/6-L !

1/14

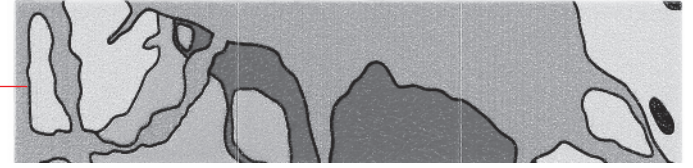
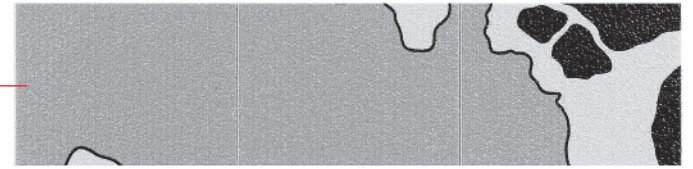
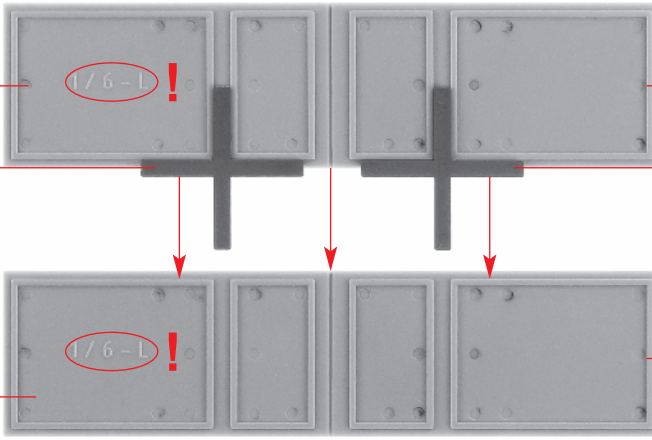

K

1/6 L (IV L)

1/4 M (VI R)

1/3 M (IV L)

1/3 M (IV L)

1/4 M (IV R)

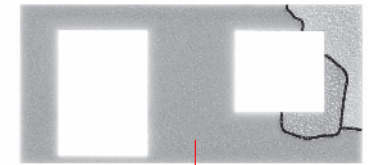
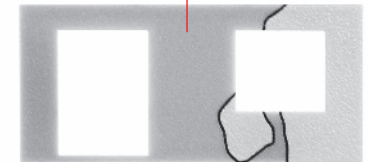
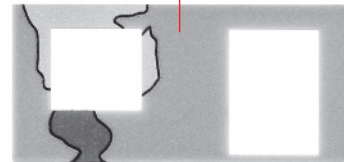
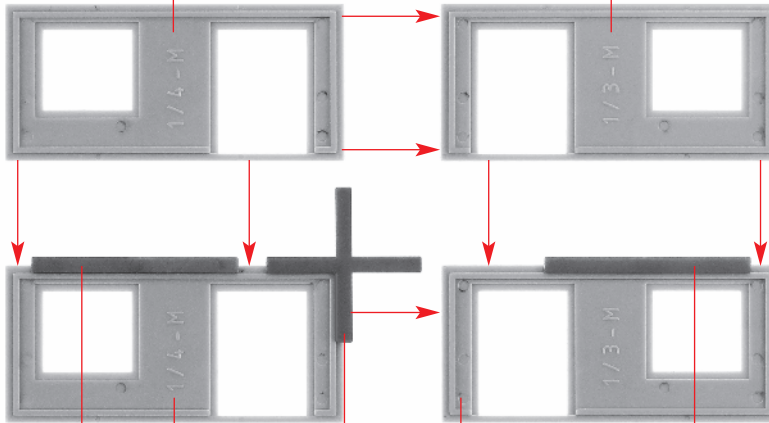

1/17

1/4 M (III R)

1/14

1/3 M (III L)

1/17

1/3 M (III L)

1/4 M (III R)

L

Fensterfolie  
Window foil  
Feuillet transparent  
Vensterfolie

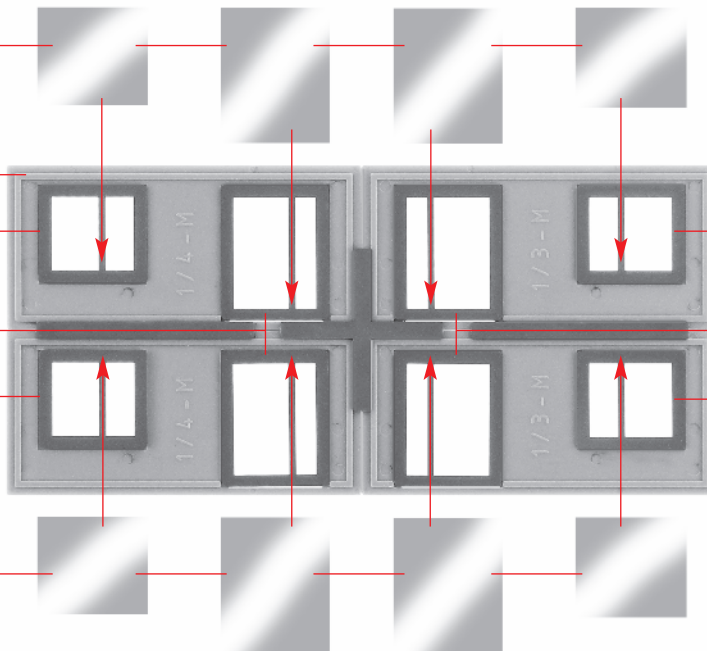

L

3/8

3/5

3/8

3/8

3/6

3/8

Fensterfolie  
Window foil  
Feuillet transparent  
Vensterfolie

M

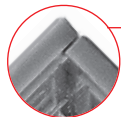

K

M

N

3/1

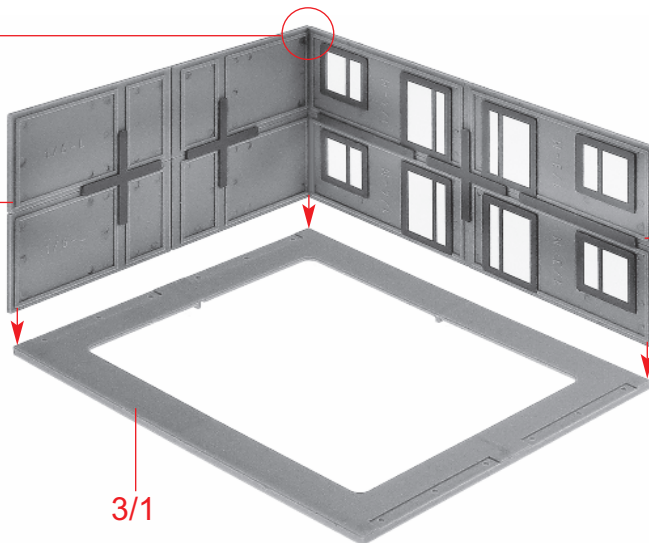

8

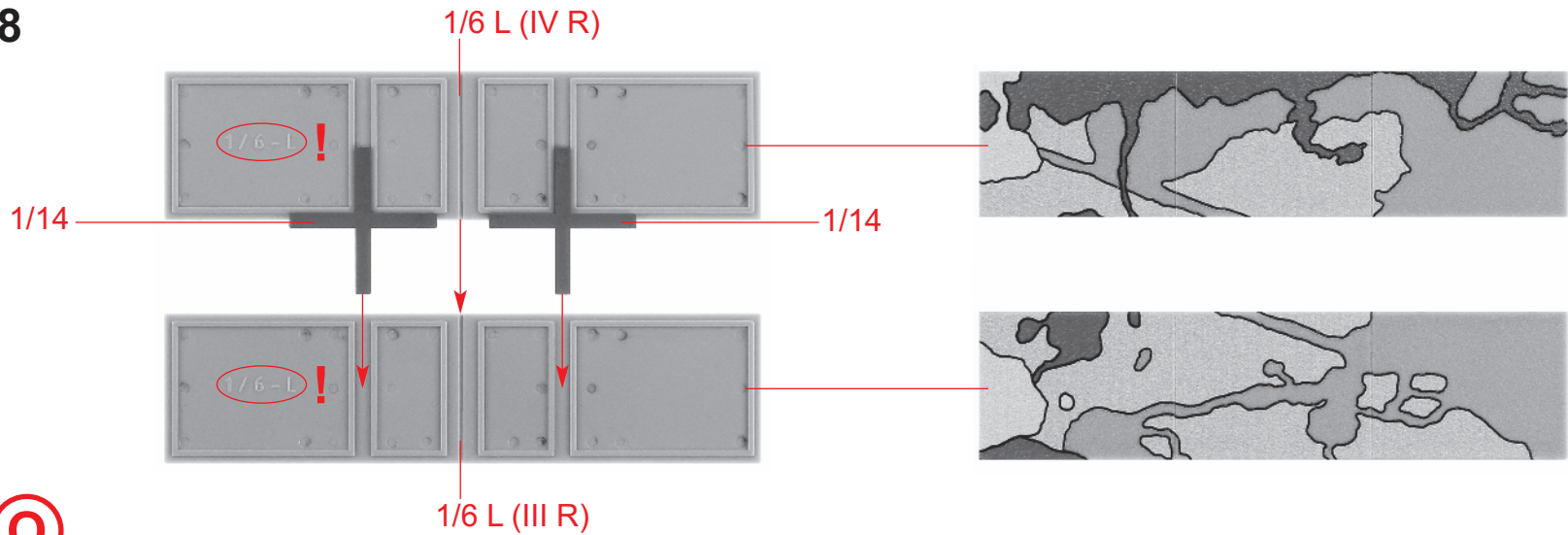

Ⓞ

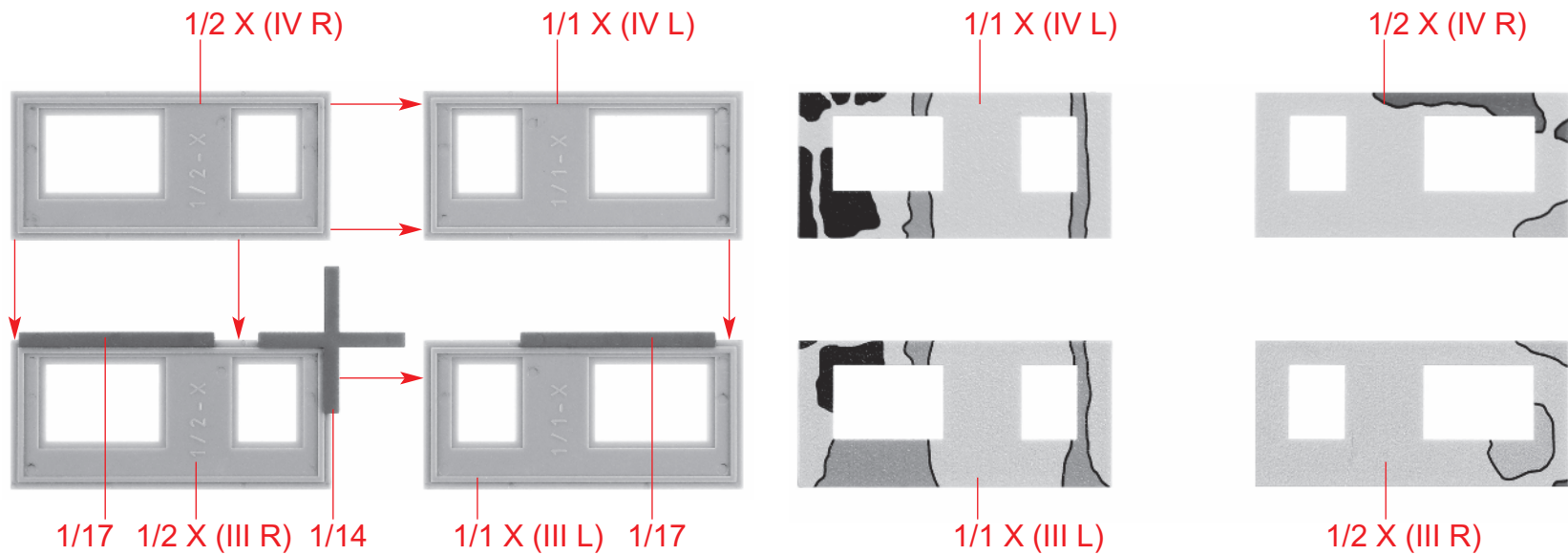

Ⓟ



Fensterfolie  
Window foil  
Feuillet transparent  
Vensterfolie

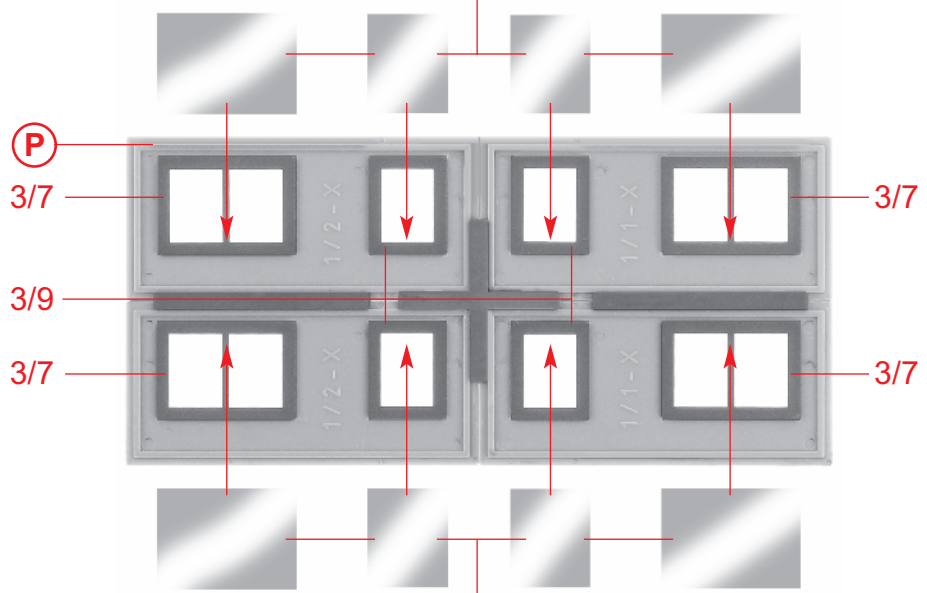

P

3/7

3/9

3/7

3/7

3/7

Q

Fensterfolie  
Window foil  
Feuillet transparent  
Vensterfolie

Papiermaske  
Papermask  
Masque  
Masker **M2**

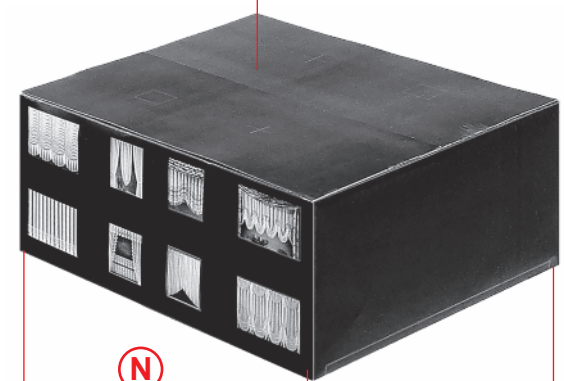

N

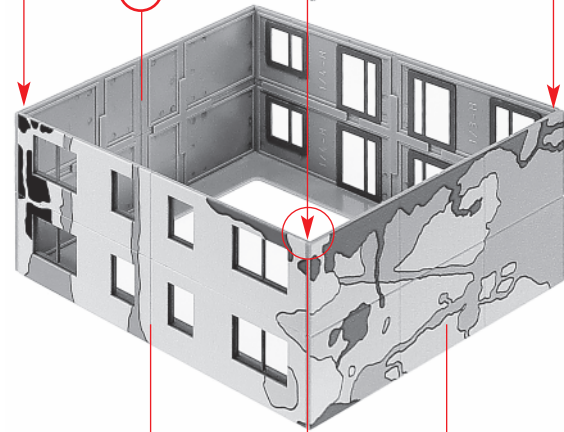

R

Q

O

10

1/5 V (VII L)



1/15



1/18

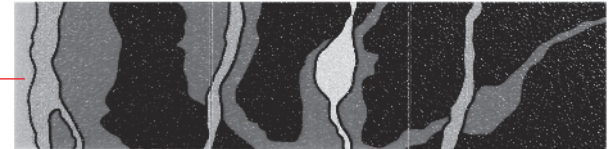

1/6 L (VI L)



1/14

1/14



1/14

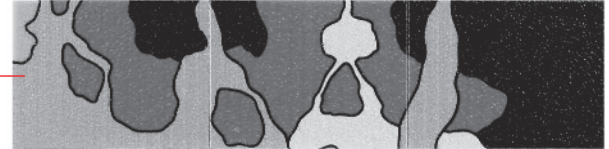

1/6 L (V L)

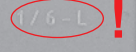

**S**

1/4 M (VI R)

1/3 M (VI L)



1/3 M (VI L)

1/4 M (VI R)

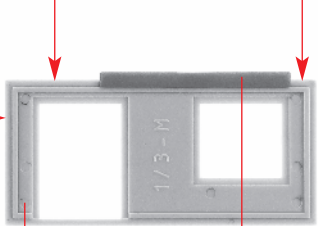
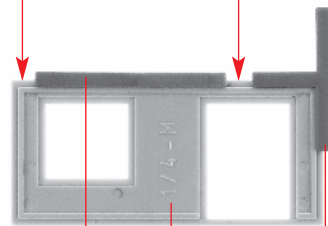
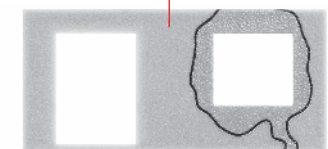

1/3 M (V L)

1/4 M (V R)

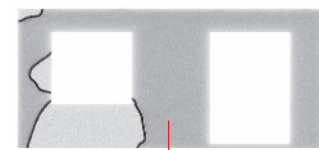

1/17

1/4 M (V R)

1/14

1/3 M (V L)

1/17

**T**

1/7 (VII R)

1/7 (VII L)

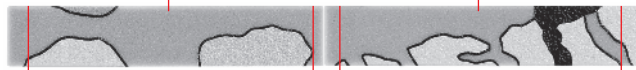

Fensterfolie  
Window foil  
Feuillet transparent  
Vensterfolie

1/18

1/17

1/17

3/8

3/8

Ⓣ

3/5

3/6

3/8

3/8

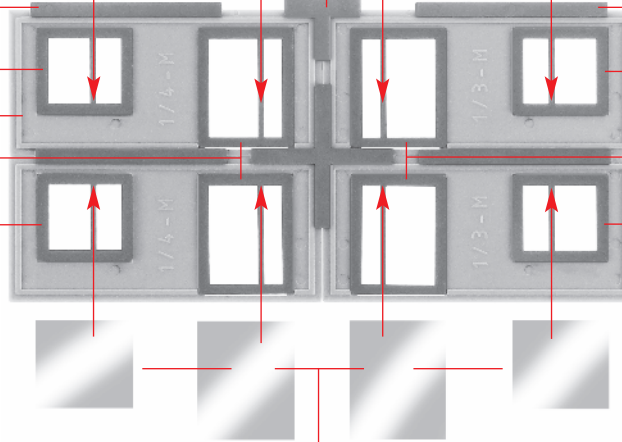

Fensterfolie  
Window foil  
Feuillet transparent  
Vensterfolie

Ⓤ

Ⓢ

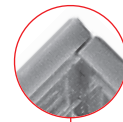

Ⓤ

11

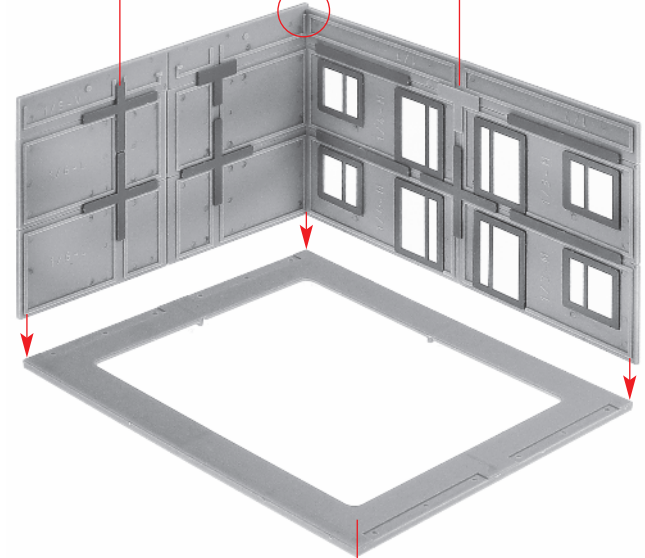

Ⓥ

3/1

12

1/5 V (VII R)



1/15

1/6 L (VI R)

1/6-L !

1/14

1/6 L (V R)

1/6-L !

1/18

1/14

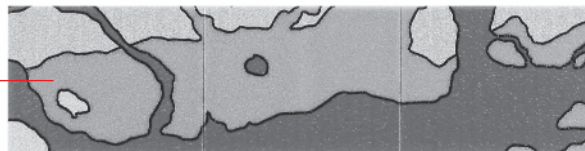
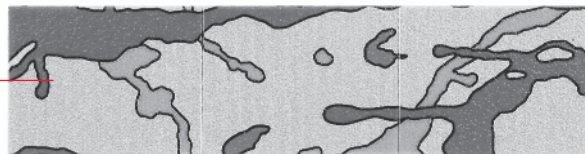

1/2 X (VI R)

1/1 X (VI L)

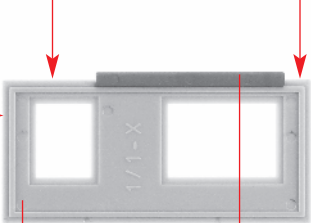
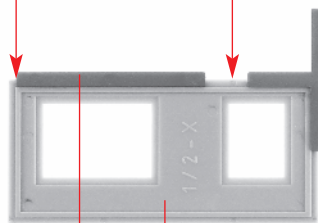

1/1 X (VI L)

1/2 X (VI R)

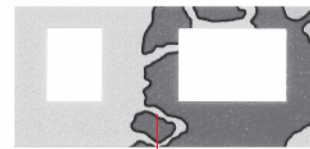
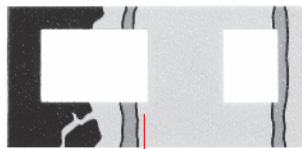
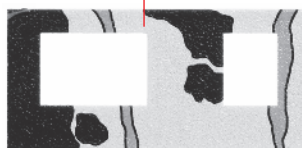

1/17

1/2 X (V R)

1/14

1/1 X (V L)

1/17

1/1 X (V L)

1/2 X (V R)



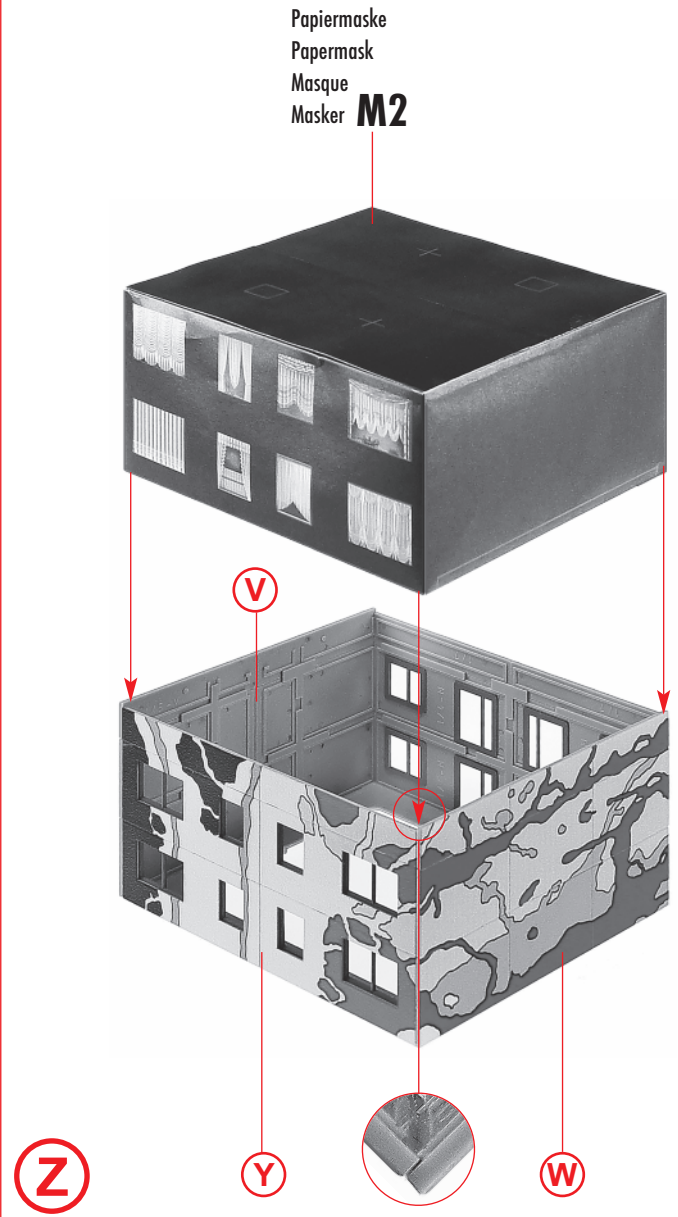
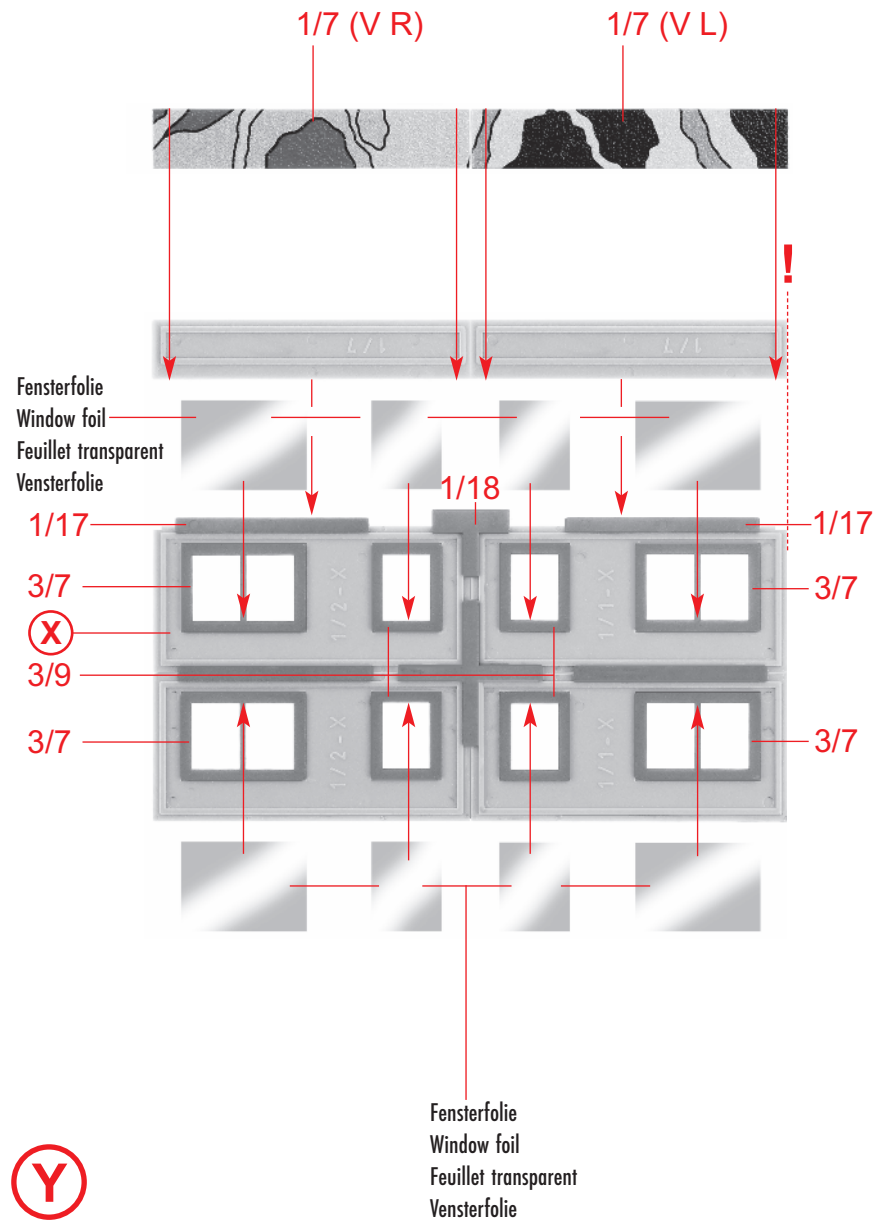

14

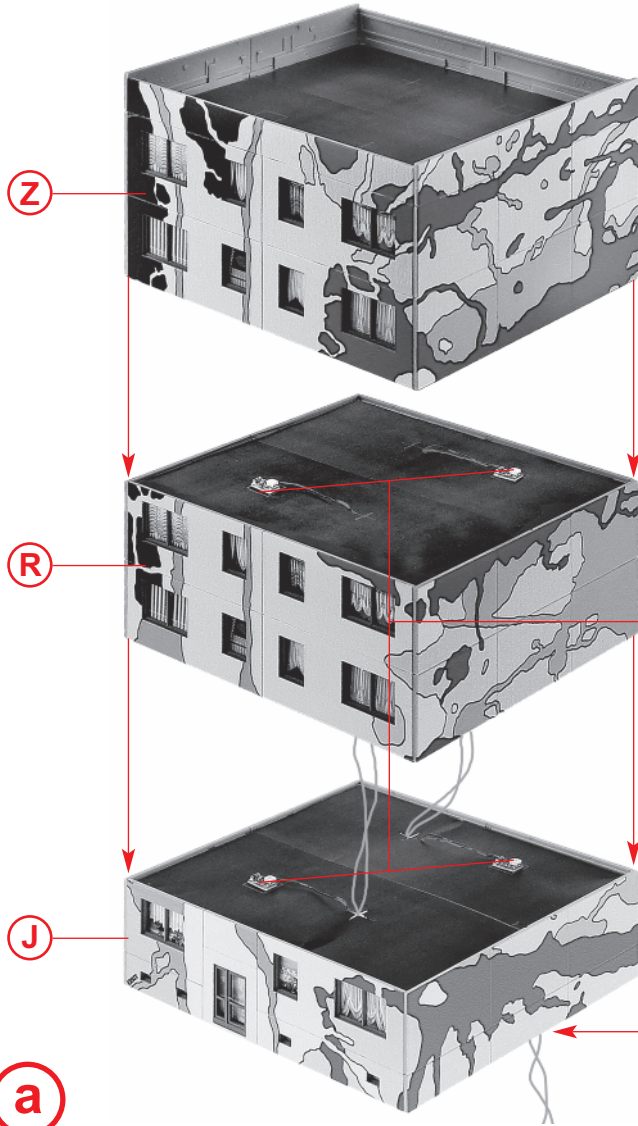

Art.-Nr. 180653  
liegt nicht bei  
not included  
non jointe  
niet bijgevoegd

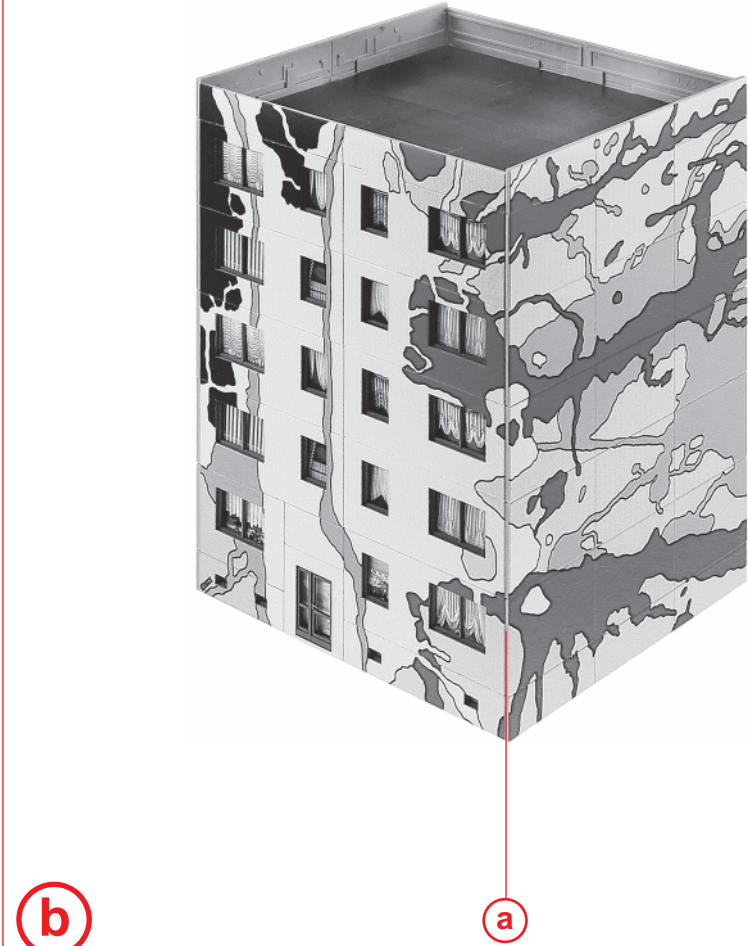

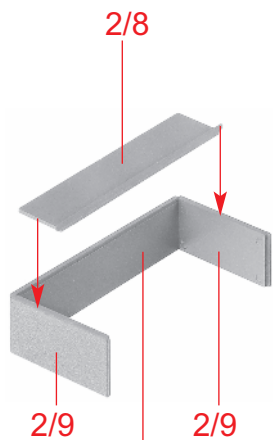

**c** 5 x 2/10

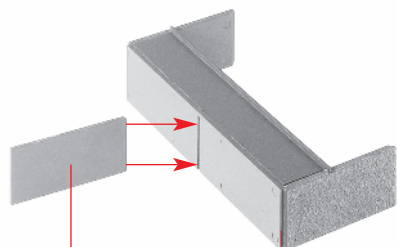

**d** 4 x 2/18

**c**

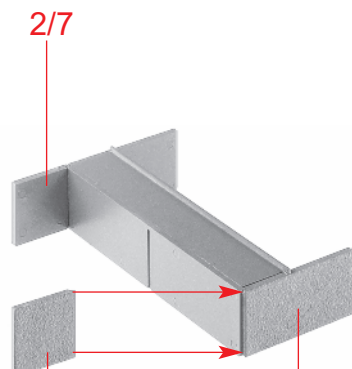

**e**

2/7

**c**

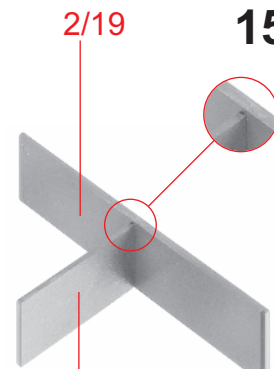

**f** 2/18

**15**

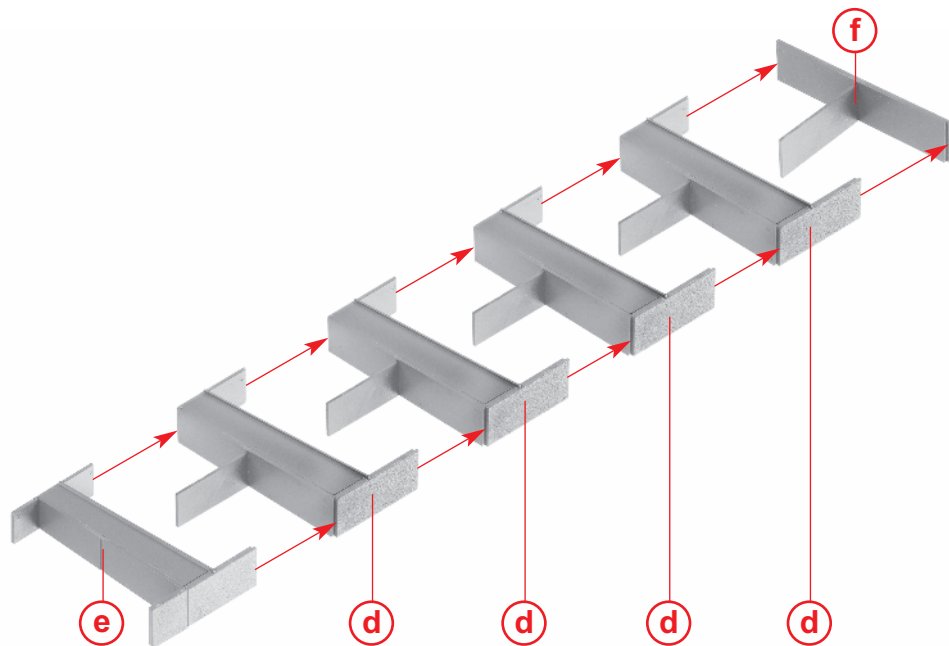

**g**

**e**

**d**

**d**

**d**

**d**

**f**

**h**

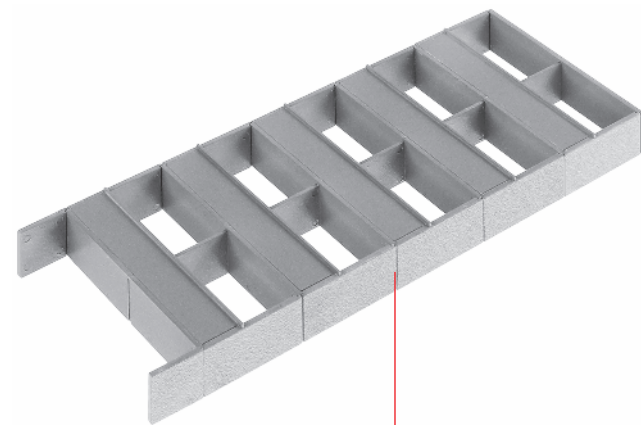

**g**

16

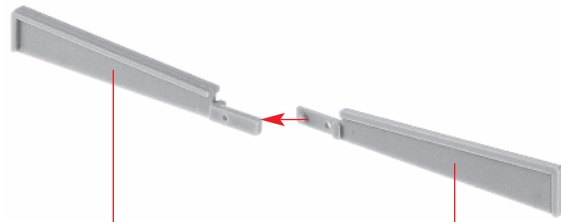

3/16

3/16

i

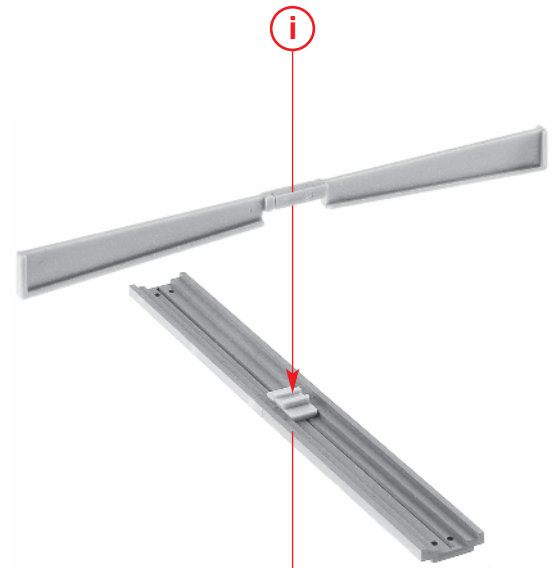

i

j

k

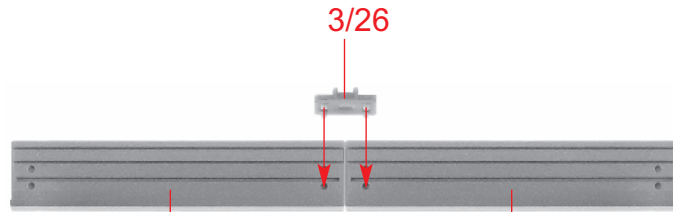

3/26

3/17

3/17

j

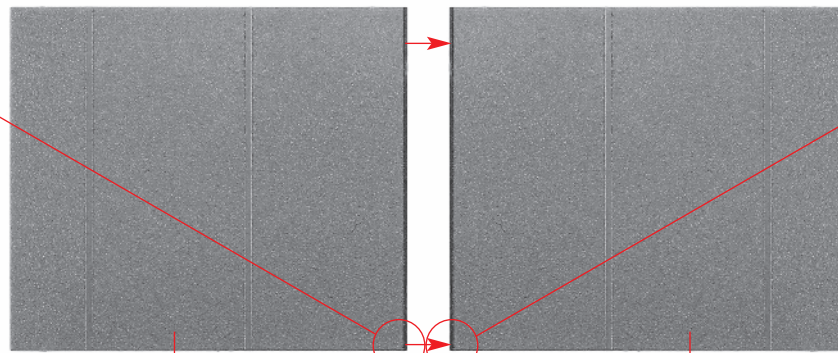
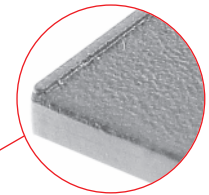
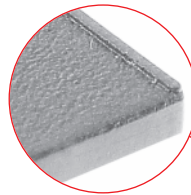

3/14

3/14

l 2 x



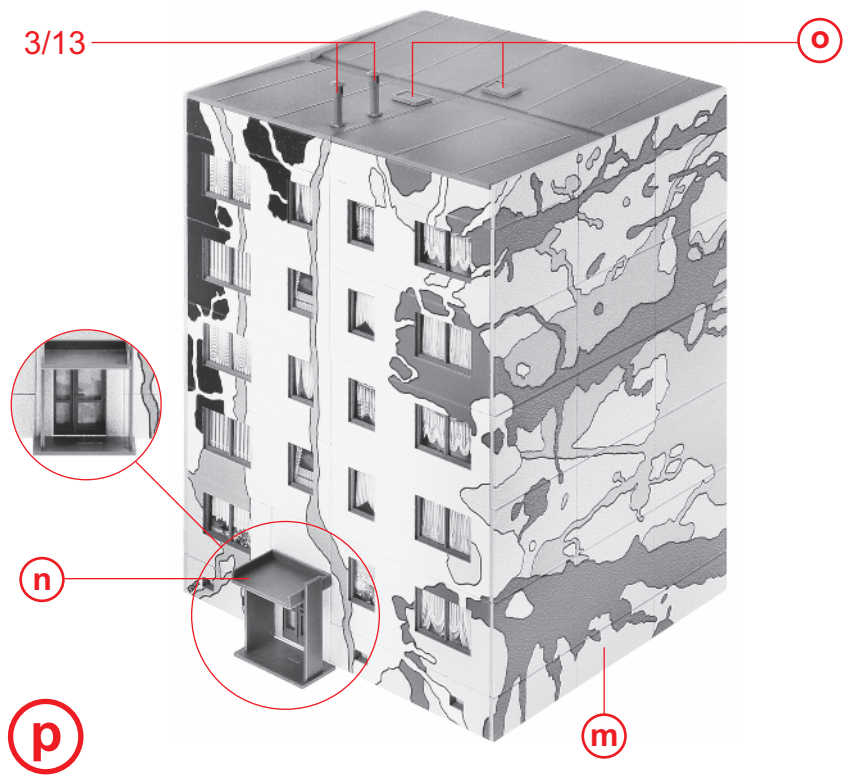
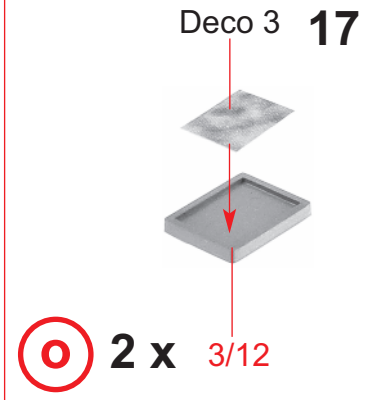
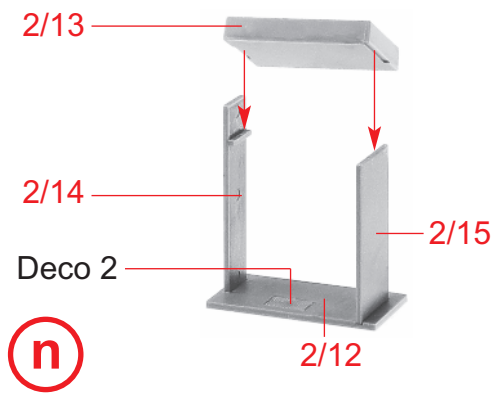
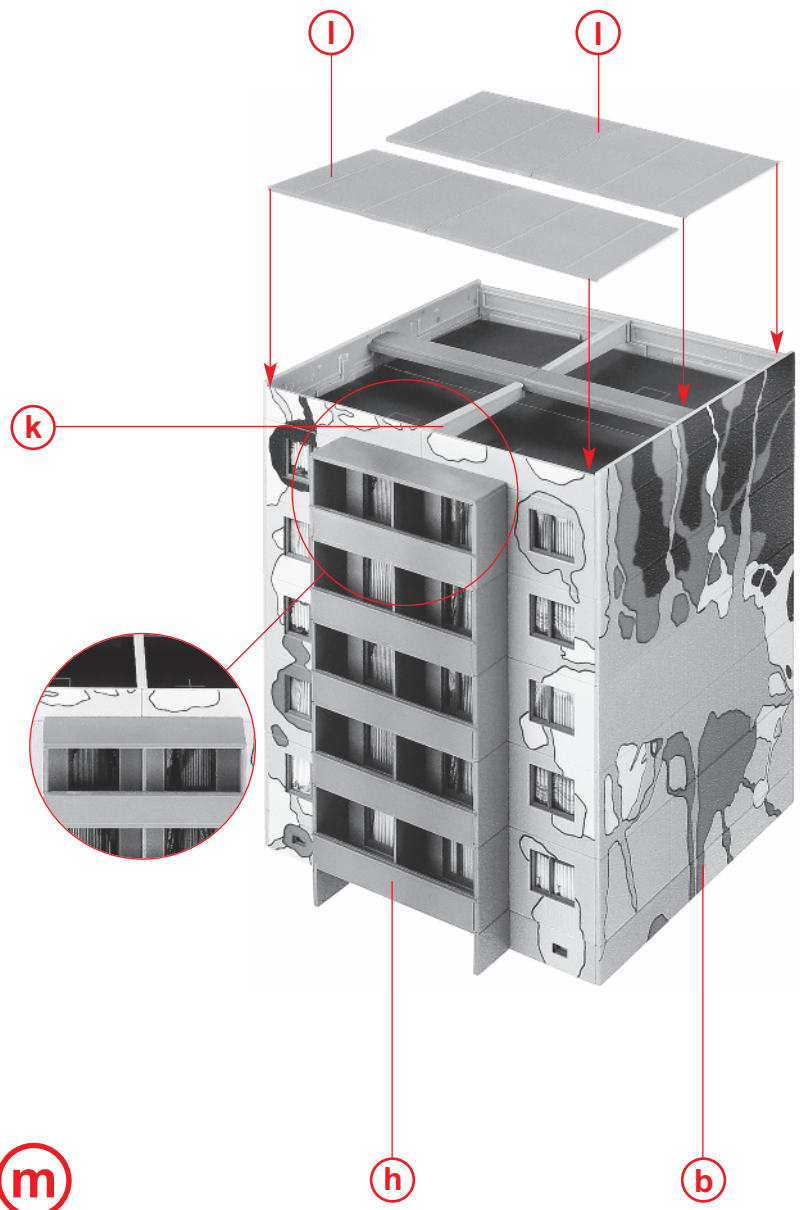

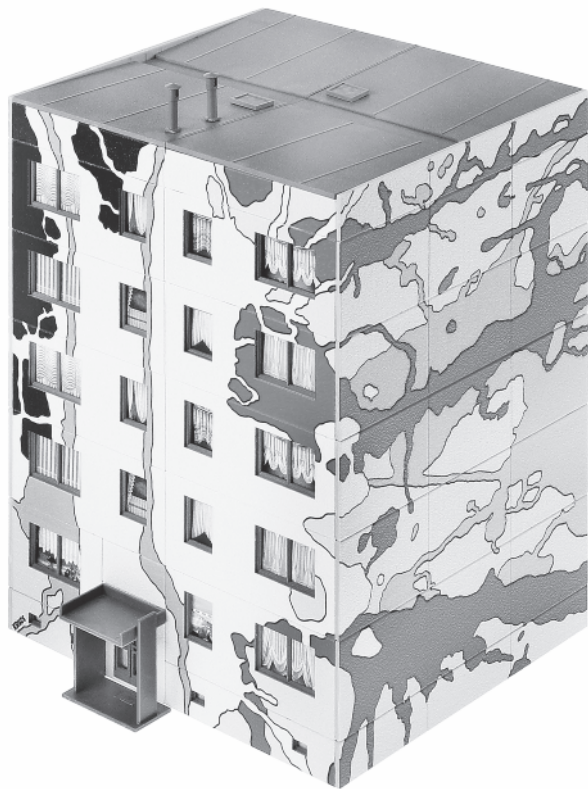

Die Zukunft ist bunt! – FALLER-Häuschen als quietschebuntes Pop-Objekt.

Limitiertes Modell des in der DDR verbreiteten Plattenbautypus P2/5 mit Digitaldruck nach einer exklusiv gestalteten Vorlage des Malers und Fassadenkünstlers Carsten Kruse.

Leuchtkraft und Dynamik der farbenfrohen Klecks-Optik stellen alle architektonischen Regeln auf den Kopf und verwandeln den nüchternen Funktionsbau in einen einzigartigen Eye-Catcher voller Leben. Weitere Infos zum Künstler unter: [www.carstenkruse.com](http://www.carstenkruse.com)

The future is colored! – FALLER houses meet pop art.

Painter and façade artist Carsten Kruse created this artwork exclusively for FALLER.

We use digital printing to apply the artwork on the limited edition of this prefabricated high-rise block. This type called »P2« was very common in the GDR.

The brilliance and dynamic of this colorful blot optics turn all architectural rules upside down and make the sober functional building a unique eye catcher full of life. For further information on the artist, please visit his website on: [www.carstenkruse.com](http://www.carstenkruse.com)

L'avenir est bigarré! – Petites maisons FALLER sous forme d'objets pop bariolés.

Modèle limité du type de HLM en préfabriqué P2/5 très répandu en RDA, avec impression numérique selon un typon dessiné en exclusivité par le peintre et artiste de façades Carsten Kruse.

La dynamique et la luminosité de l'aspect tacheté haut en couleur renversent toutes les règles architecturales et transforme la construction fonctionnelle dépouillée en un tape-à-l'œil plein de vie unique en son genre. On trouvera de plus amples informations sur l'artiste sur le site [www.carstenkruse.com](http://www.carstenkruse.com)

De toekomst is kleurrijk! FALLER gebouw als buitengewoon bont pop-object.

Model in een beperkte oplage van de in Oost-Duitsland wijdverbreide »plattenbau« type P2/5, dat digitaal is bedrukt met een door schilder en gevelartiest Carsten Kruse exclusief voor Faller ontworpen afbeelding.

De helderheid en dynamiek van dit kleurrijke schouwspel zetten alle architectonische regels op z`n kop en veranderen dit grauwe woonblok in een unieke eye-catcher vol leven. Meer informatie over de artiest onder: [www.carstenkruse.com](http://www.carstenkruse.com)



Art. Nr. 130803

Plattenbau P2/5  
 Prefabricated High-Rise P2/5  
 HLM en préfabriqué P2/5  
 Plattenbau P2/5



Art. Nr. 180424

Berliner Mauer  
 Berlin Wall  
 Mur de Berlin  
 Berlijnse muur

# Modellbau leicht gemacht

## Klebstoffe für den Profi-Modellbauer



**170490**

**SUPER-EXPERT**

**25 g**

Seit über 10 Jahren werden die FALLER EXPERT-Klebstoffe angeboten. Dieser Klebstoff für den Profi reagiert schneller, klebt schneller und dauerhafter. Mit Spezialkanüle und Kanülenschutzkappe.



**170492**

**EXPERT**

**25 g**

Dieser Klebstoff wird nach einer neuen Rezeptur hergestellt, das sorgt für optimale Klebresultate. Die Spezialkanüle ermöglicht eine besonders feine Klebstoffdosierung. Der Klebstoff kann in kleinsten Punkten, auch an schwer zugänglichen Stellen, auf die zu klebenden Teile aufgetragen werden.



**170500**

**Modellbaukleber**

**10 g**

für blitzschnelle Klebearbeiten. Dieser Sekundenkleber (Cyanacrylat) besitzt verbesserte Klebeeigenschaften, fließt in kleinste Spalten und neigt weniger zum Kriechen. Damit lassen sich fast alle Klebeverbindungen herstellen. Kühl und dunkel lagern.